

General Catalogue

IT Equipment Solution

ABOVE THE STANDARD

RACK EQUIPMENT
INROW
INROOM
CONDENSING UNIT

ABRA

IT Catalogue Guideline

·		
·		
·	· ·	Nomenclature 6
·		
·		
·	· · ·	Introduction 8

IT Equipment Solution

·		
·		
·	· · · ·	Rack systems 15
·		
·		
·		
·	· · · · ·	Rack Accessories 20
·		
·		
·	· · · · · ·	Modular PDU 29

IT Cooling Solution

·
·
· · In-Row Cooling System 39
·
·
·

· · · In-Room Cooling System 58
·
·
·

· · · · Condensing Unit 67

The world depends on data, we power and cool. From a simple swipe, to life-changing medicines. From push notifications to generative AI.

Where there's data, there's ABRA. Powering its potential. From pioneering precision cooling, to ABRA's leadership in critical infrastructure.

And the more data created, the more ABRA technology is needed. From supercomputers powering artificial intelligence, to modular data centers enabling fast-track deployment.

We're powering the potential for tomorrow's breakthroughs. ABRA's scale and innovation is accelerating the industry. From empowering what data needs now, to cooling where data goes next. As AI heats up, leading chip makers turn to us to keep them cool. What's next?



A sustainable digital future enabled by ABRA. Join us at the edge of innovation, supercharging data's next move.

Because the best way to predict the future, is to power it.

Nomenclature

Indoor Unit

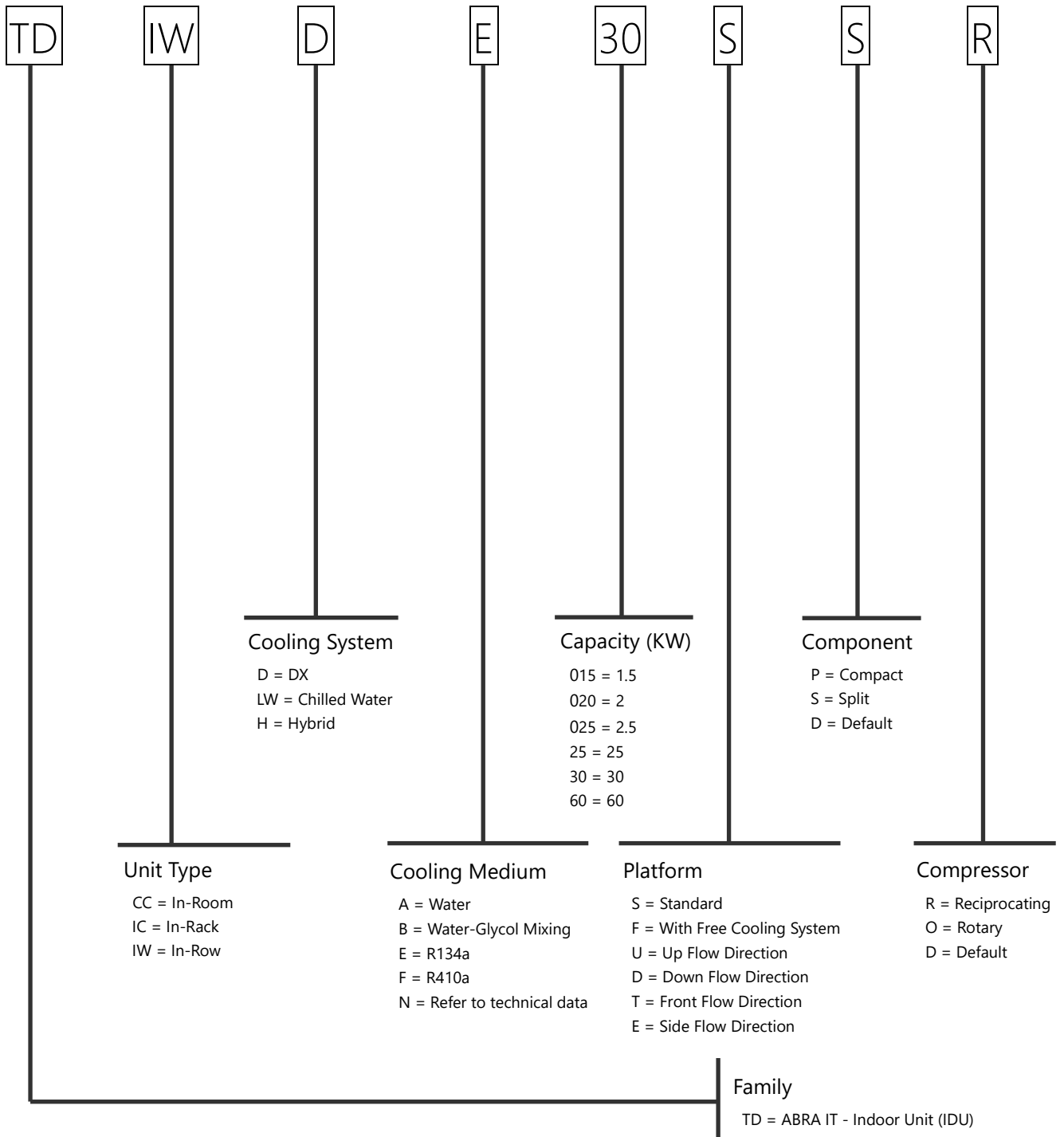

X X X X X



Option codes will be added to the end of the nomenclature respectively.

Outdoor Unit

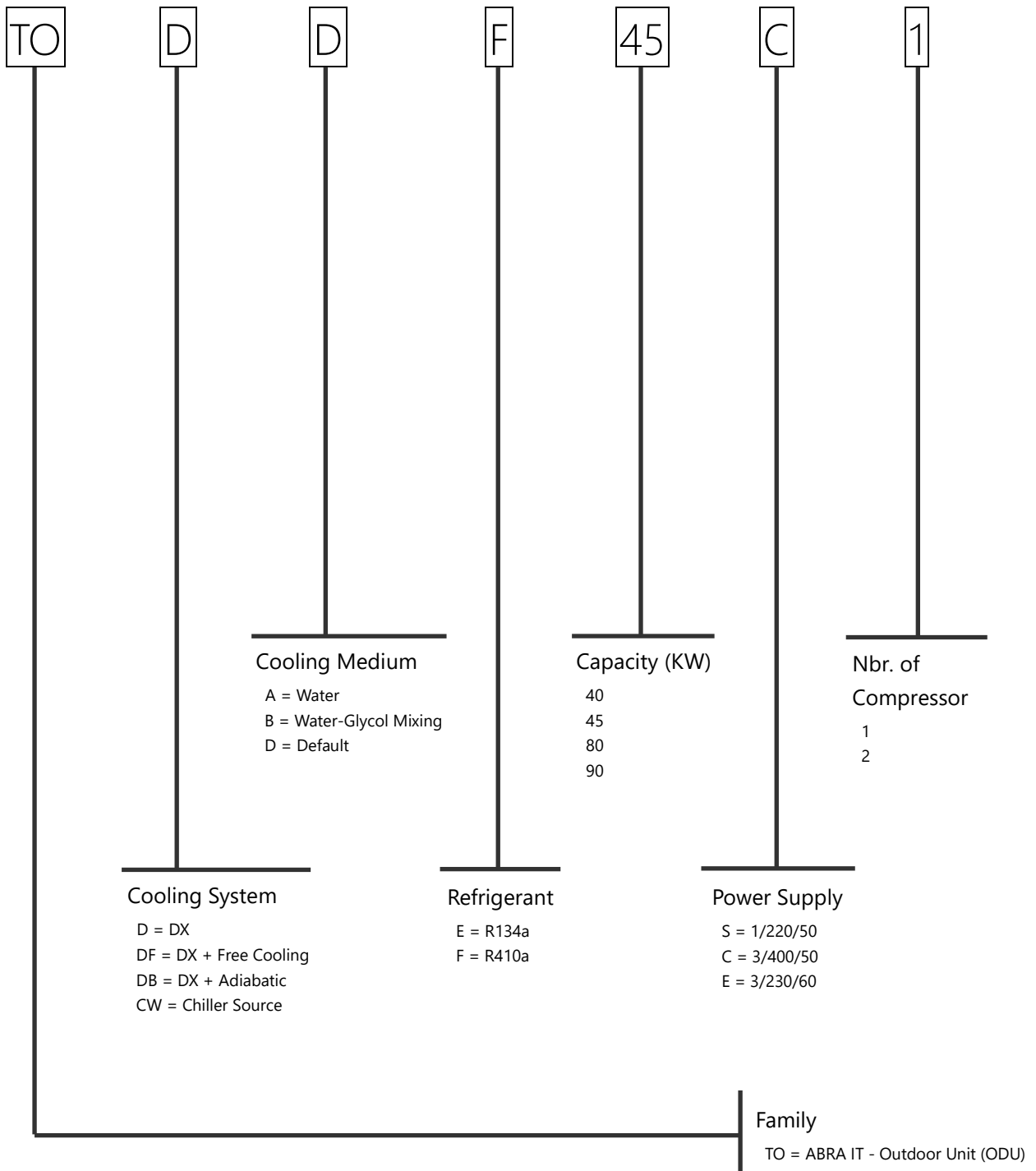

X X X X X



Option codes will be added to the end of the nomenclature respectively.

Introduction

Proper cooling is crucial to the operation of IT equipment, including servers, storage, and networking devices. As more companies undergo digital transformation, they need edge data centers that include robust, reliable compute resources located close to where data is being generated and processed. Edge computing is the concept of having compute and storage capacity close to where users are generating, consuming and manipulating data. Internet of Things (IoT) applications, for example, involve devices and sensors generating significant amounts of data at the network edge that must then be processed. Legal requirements, the need for local data consolidation and, above all, the high network costs, latency and network security lead to an enormous growth in decentralized IT, the edge applications. The latency involved in sending it to a centralized or cloud data center is too long, driving the need for localized processing capabilities. Healthcare, factory floor machine control and “smart city” applications including autonomous vehicles are just a few examples of applications driving demand for edge computing and, hence, edge data centers.



Office Environments and Comfort Cooling

The typical office environment uses room-based cooling systems provided by building heating, ventilation and air conditioning (HVAC) systems or de-centralized mini-split cooling systems. In centralized building HVAC systems, the cool air enters the space through vents in the ceiling or floor, while warm air is funneled back to the cooling system through a separate return duct. In de-centralized cooling systems extensive ductwork is not needed because the air conditioner is located in the cooled space on or near an outside wall. While this setup works fine in general, as any office worker knows, some areas may be warmer or cooler than others, especially with the centralized HVAC systems. That's a function of the way such systems work, having a single thermometer setting the desired temperature for what may be a fairly large area, such as an entire floor or multiple rooms. But the building's configuration, and the direction that different windows face, may mean some areas warm up more so than others. These differences, however, are not usually large enough to make for uncomfortable, comfort cooling temperatures one way or the other. Putting IT equipment into such a space can change that equation; looking at cooling requirements for office buildings versus data centers helps illustrate why. Cooling capacity is calculated based on the heat load the cooling system needs to handle, typically measured in watts (W) or kilowatts (kW). A typical office HVAC system should have cooling capacity to deal with a heat load in the range of 50 to 150 W per square meter. But a single rack of IT equipment may produce a heat load of up to 7500 watt per square meter.

That is likely to have several repercussions:

- Employees may be uncomfortable as the system struggles to maintain a target temperature, especially in the areas closest to where the IT rack sits
- IT equipment such as servers often have thermal protection systems that trigger a shutdown if the temperature rises too high, causing disruptive downtime and raising the potential for lost and corrupted data
- Continually taxing the HVAC system to operate above its rated cooling capacity will drive up operating costs, over the long-term



Another issue with typical office buildings is humidity. Office HVAC systems aren't designed to hold a constant level of humidity. With doors and potentially windows opening and closing all the time, humidity levels can constantly change depending on conditions outside. The HVAC system will only keep humidity in check at a general level, as a function of providing comfortable heating and cooling, not at exact levels. That may not be good enough for IT equipment, which is highly susceptible to changes in humidity. High humidity can cause condensation and water droplets to form on metal surfaces, eventually leading to corrosion. On the other hand, low humidity can cause static discharge from IT equipment, which may result in damage to electronics such as hard drives. Similarly, dust is the enemy of IT gear. That's why purpose-built data centers have air filtration systems that remove dust and other particulates from the air. In an office environment, dust will naturally accumulate on any surface that's not at least occasionally cleaned, including inside servers and other IT equipment. Over time, this accumulation could impede proper functioning of the equipment.



IT Cooling Options for Office Environments

Companies have two general options for overcoming these obstacles and providing proper cooling for IT equipment installed in an office environment:

- Dedicated room cooling
- Spot-cooling
- Rack-cooling
- Row-cooling

In either case, a key consideration is the equipment footprint.

Companies typically have limited space to dedicate to IT equipment in the first place, often carving it out of space previously dedicated to another purpose. Air cooling systems for such spaces need to be designed to take up as little floor space as possible.

Dedicated Room Cooling

One option is to take a defined amount of space and turn it into a room dedicated to IT equipment, often called a server room. You can then install a cooling system dedicated to the sole purpose of cooling the IT equipment in that room.

Such a system can address the shortcomings of the building HVAC system, including humidity control and particulate filtration. Multiple options exist, enabling companies to choose one that best fits their exact situation.

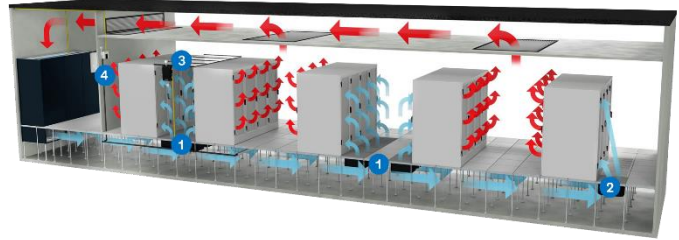

For cooling the entire room, the two main options are floor-mounted and ceiling-mounted cooling units. In either case, these are typically split systems provided by DX or chilled water that mounted in the IT facility, which are called In-Room systems.

Spot Cooling

However, in edge facilities especially, it's not always possible or practical to create a dedicated server room and some users need to install the IT equipment directly in the office space. In such cases, spot cooling is a good option, with options falling into two general categories: rack- and row-based cooling.

Rack cooling systems can be installed in a perforated door rack or a two-post rack without a door. Such systems also provide some room cooling, making them more suitable for dedicated server rooms or network closets. The systems typically have cooling capacity of about 2-4 kW per rack.

Rack-based Cooling

Rack-based cooling is good for smaller installations of just one or two racks of IT equipment. It involves a cooling system that's integrated directly into the rack and cools only that rack.

The racks can be enclosed, or contained, such that the cool air doesn't get dispersed into the room. This is a good option in office installations because it separates IT cooling from office cooling, so they do not impact each other. IT cooling won't make it uncomfortably cool for people in the office, and the warmer office air won't hinder the effectiveness of the IT cooling system.

A rack-based system has a self-contained unit that disperses cool air to the IT load, then circulates the resulting warm air back to the cooling unit. Enclosed Rack Cooling Does not require dedicated server room. It can be installed in office or industrial space.

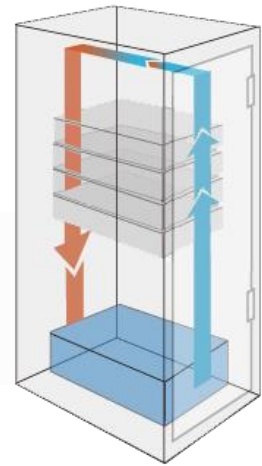

Row-based Cooling

For applications with more than one rack, another option is row-based cooling. These are typically split systems that use an outdoor condenser unit and an indoor evaporating unit. The indoor component comes in a form factor that enables it to fit seamlessly into an IT rack, with the ability to cool several racks in the row.

Row systems can also be contained, similar to enclosed rack systems so that the IT cooling air is circulated only inside of the racks and not discharged into the room. This configuration is ideal for users that don't have a dedicated server room but need to have more than two racks installed in an office space.

Here again, an open version with perforated rack doors is available as well and is used mainly in dedicated server rooms.

Row-based systems disperse cool air through the front of server rows and send warm air out the back, typically to an outdoor condenser unit where it is cooled again. They can be configured as fully contained systems or with perforated doors for room cooling.

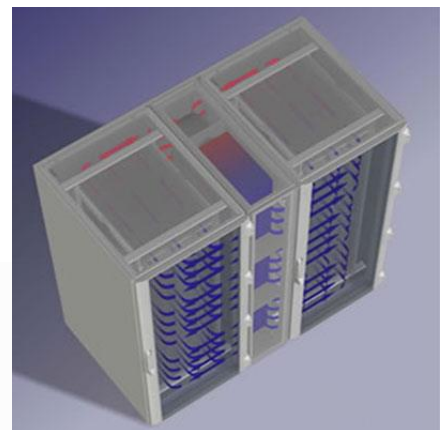

One of the benefits of row-based cooling is it's installed close to the IT equipment, which allows for short air paths and quick system reactions to changing heat loads. The system continuously adjusts its cooling capacity and airflow to match the actual server load at any given time. This helps to keep operating costs low by giving the IT equipment only the cooling capacity it needs. Some systems can monitor temperatures of up to 10 different racks and adjust their cooling performance to make sure each rack is getting enough cold air. Such a capability makes these systems a good fit for applications with varying levels of server density.

Heat Rejection Options

As the cooling system cools the room, it removes the heat from that space, and this heat has to go somewhere. There are several options available for how the heat can be rejected, and each application may require different heat rejection types, like the popular methods of air, water, and refrigerant. This may dictate which cooling system is the best match for a given space.

One simple way of heat rejection is through the existing duct system in a building. This is a viable option for smaller rack-based cooling systems that generally produce a relatively small amount of warm air if a building duct system is available and suitable for it. Unfortunately, in many situations this is not the case.

Row- and room-based systems require a different approach since their cooling capacities are bigger, and consequently, they also remove more heat from the room. The existing building duct system would not have the capacity to absorb all this rejected heat. Therefore, these systems always consist of an indoor and outdoor unit connected with two pipes. Depending on heat rejection type, there can be either refrigerant or water flowing in these pipes between indoor and outdoor units.

Direct expansion (DX) systems use refrigerant to transport the heat removed by the indoor unit into the outdoor unit called the condenser, where it is rejected into the ambient air. A DX System is a practice used most commonly with home air conditioning systems.

Chilled water systems use water to transport the heat removed by the indoor unit. The chilled water type of indoor unit is connected to an outdoor chiller plant. The Chiller plant removes the heat from the water, cools it, and sends it back into the indoor unit, which uses it to cool the room. Chilled water systems are typically used in applications with higher heat loads because a single chilled water row-based indoor unit can provide from 30 to 60kW of cooling capacity. In practice, most companies would not build a chiller plant for small sites since it's quite expensive. Therefore, for smaller locations, DX systems are typically preferred.

Uncontrolled Environments

Aside from office environments, many companies need to install edge data centers on factory floors, in manufacturing facilities, and in warehouses that have widely varying environmental characteristics.

Any warehouse faces challenges in maintaining a constant temperature since they aren't usually well-insulated. Depending on geographic region, that can lead to excessive heat or cold inside the facility. Facilities located in regions with changing seasons will see wide fluctuations in terms of temperature from hot to cold and back again. Humidity is likewise an issue for all the same reasons, especially in facilities with no ambient air control system in place.

Uncontrolled environments are also likely to be far dustier than offices, and less likely to have any particulate filtration system in place. Dust combined with high humidity can be quite harmful to IT equipment, as the humidity will make particles stick to IT equipment and potentially clog up the filters meant to protect gear such as servers and data storage systems.

Cooling Options

Theoretically, all the same cooling systems that apply in an office environment can also be used in uncontrolled environments, but most customers favor an approach that involves a sealed rack, which means rack- or row-based cooling.

The reason is simple: such self-contained systems essentially seal off the IT equipment from the outside air. That protects the equipment from dust and humidity, while enabling the company to tightly control the temperature of the racks.

The key is to look for a system with a high Ingress Protection (IP) rating as defined in the International Electrotechnical Commission (IEC) 60529 specification, which covers mechanical and electrical enclosures intended to protect against intrusion, dust and water. An IP54 rating, for example, means an enclosure offers strong protection against dirt, dust, oil, and splashing water, all enemies of IT equipment.

With such an enclosure, the IT equipment is isolated from the environment in which it's installed. Combined with a rack- or row-based cooling system, companies can tightly control the temperature of the IT equipment while also protecting it from its potentially harsh surroundings.

Such a setup can also be highly efficient since IT equipment can withstand far higher temperatures than what is comfortable for humans. For example, the latest guidance from the American Society of Heating, Refrigerating and Air-Conditioning Engineers (ASHRAE) says 87 percent of server models are safe to operate at 35 degrees Celsius (95 degree Fahrenheit). Operating the IT cooling system at or near that level would save significant sums on cooling costs versus using a temperature closer to the comfort level for humans.





Rack systems

For converged IT

Ready for high-density and edge environments right out of the box, ABRA enclosures offer the most standard features on the market today. These enclosures are engineered to handle a broad range of applications from power-hungry, high-density server and networking applications to remote edge computing applications. ABRA racks are packed with features that make installation faster and easier and reduce handling after installation.



- Cable access through roof and rack bottom
- Adjustable vertical mounting rails
- Lockable doors and side panels
- Rear accessory mounting brackets for easy integration of rack PDU and cable managers



More Standard Features for Faster Installation

Organizations often need solutions for delivering fully populated IT racks. Special packaging options for ABRA enable integrators to “rack and stack” the solution for a truly end-to-end converged system delivered prebuilt, pretested, racked and shipped to its final destination.

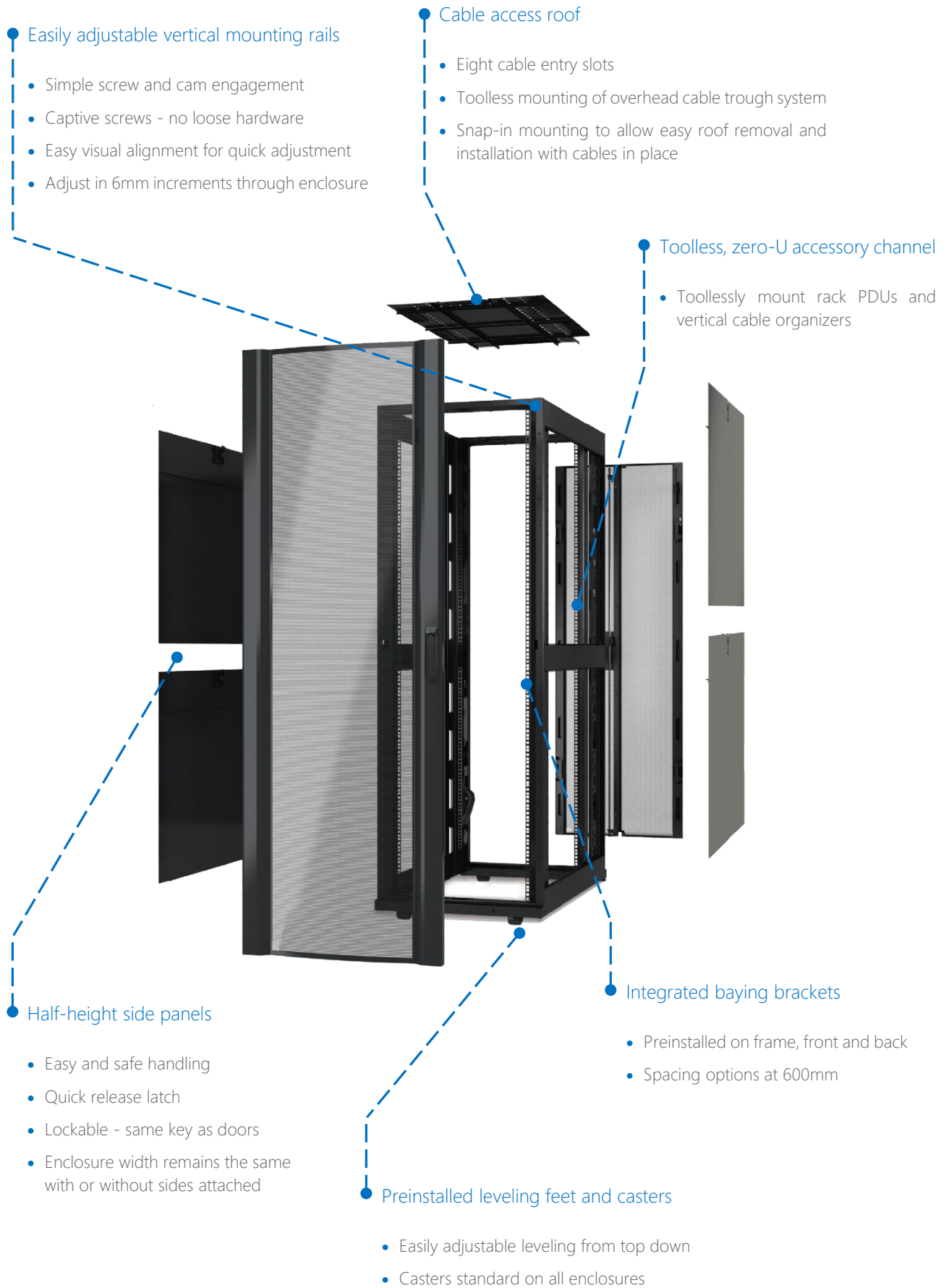

- Easily adjustable vertical mounting rails
 - Simple screw and cam engagement
 - Captive screws - no loose hardware
 - Easy visual alignment for quick adjustment
 - Adjust in 6mm increments through enclosure

- Cable access roof
 - Eight cable entry slots
 - Toolless mounting of overhead cable trough system
 - Snap-in mounting to allow easy roof removal and installation with cables in place

- Toolless, zero-U accessory channel
 - Toollessly mount rack PDUs and vertical cable organizers

- Half-height side panels
 - Easy and safe handling
 - Quick release latch
 - Lockable - same key as doors
 - Enclosure width remains the same with or without sides attached

- Integrated baying brackets
 - Preinstalled on frame, front and back
 - Spacing options at 600mm

- Preinstalled leveling feet and casters
 - Easily adjustable leveling from top down
 - Casters standard on all enclosures

Features

Best-in-class Design

- Offers most standard features to facilitate installation and speed of deployment
- Integrates seamlessly with the full line components

Greatest Flexibility

- Available in a wide range of heights, widths and depths to meet a variety of data center and edge computing applications
- Rapid installation of vertical rack PDUs in the rear vertical zero-U accessory channel

Superior Cable Management Capabilities

- Accommodates high density networking and blade applications
- Easy installation to enable faster and easier moves, adds and changes
- Promotes proper airflow to improve cooling efficiency

Rack Components

1. Roof
2. Rear doors
3. Removable top side panel (locking)
4. Removeable bottom side panel
5. Zero U accessory mounting brackets
6. Cabinet frame
7. Casters
8. Front lockable door

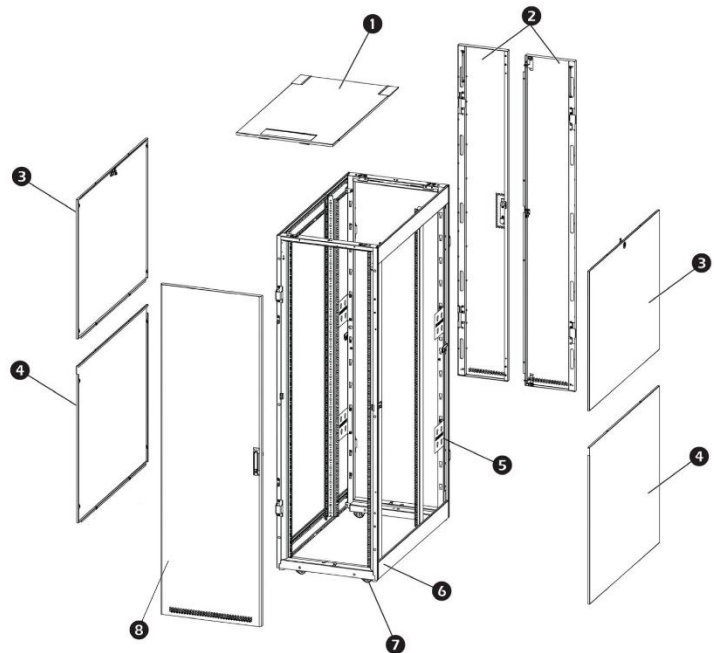

Model no.	Rack Units	Height	Width	Depth	Doors	Sides
Unit	-	mm	mm	mm	-	-
ASR1L	42	1990	600	1100	✓	✓
ASR1M	42	1990	750	1100	✓	✓
ASR1H	42	1990	800	1200	✓	✓
ASR2L	48	2250	600	1100	✓	✓
ASR2M	48	2250	750	1100	✓	✓
ASR2H	48	2250	800	1200	✓	✓
ASR3L	52	2450	600	1100	✓	✓
ASR3M	52	2450	750	1100	✓	✓
ASR3H	52	2450	800	1200	✓	✓

- The base of the racks is adjustable up to 2 centimeters for leveling.

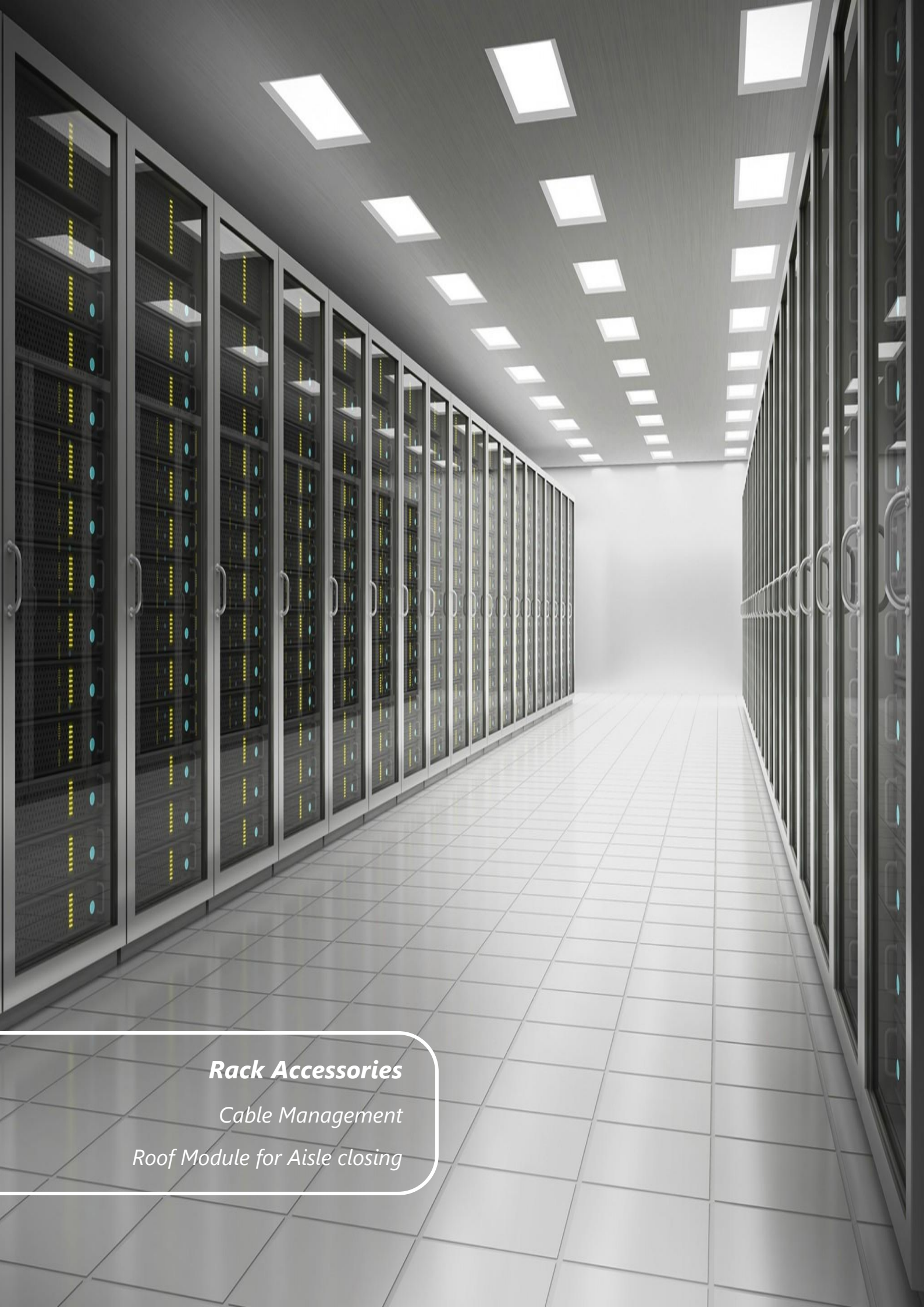

Rack Accessories

Cable Management

Roof Module for Aisle closing

Cable Management

Vertical Cable Management

Every ASR enclosure contains zero-U accessory channels in the rear of the rack. Use these to toollessly mount vertical rack PDUs and vertical cable organizers.

Model	Description
ASR1	Vertical 0U accessory channel, 42U, 2 pack
ASR2	Vertical 0U accessory channel, 48U, 2 pack
ASR3	Vertical 0U accessory channel, 52U, 2 pack

Model	Description	Features
ASR8442	Vertical cable organizer, eight cable rings, 0U	Supports 35 to 55 CAT 6/CAT 6A data cables Mounts toollessly on the vertical 0U accessory channel
ASR8443A	Vertical fiber organizer	Installs toollessly Takes up one bay of channel Fiber spool only kit available (ASR8444)
ASR8457	Data distribution 0U SX panel	Installs toollessly Takes up one bay of channel Toollessly mounts up to four DDC cable heads, 24 ports for rack-to-rack connections
ASR7710	Cable containment brackets with rack PDU mounting	Low-profile vertical cable management Supports 60 to 90 CAT 6/CAT 6A data cables Mounts toollessly on the vertical 0U accessory channel
ASR7711	Zero-U accessory bracket	Mounts rack PDUs in rear-facing orientation Supports third-party accessories in numerous mounting configurations Mounts 1U or 2U patch panels or other networking accessories
ASR8621	Hook-and-loop cable managers, 10 pack	Secures and bundles cables with hook-and-loop ties Mounts toollessly on the vertical 0U accessory channel
ASR7721, 22, 23	Low-profile vertical cable managers, zero U	Supports up to 38 CAT 6A or 251 fiber cables Mounts toollessly on the vertical 0U accessory channel

Model	Description
ASR7580A	High-capacity vertical cable manager for Rack 30 in. wide enclosures (ASR3x5x) supports 190 to 250 CAT 6A/CAT 6 data cables per section and 190 CAT 6A per channel section.
ASR7581A	Hinged covers for ASR7580A vertical cable managers.

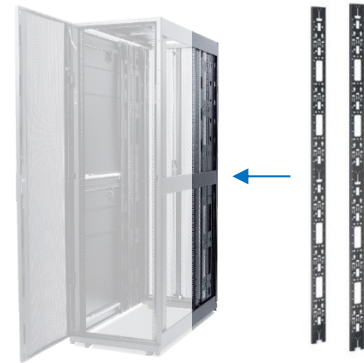

ASR8443A

ASR7721



ASR8444

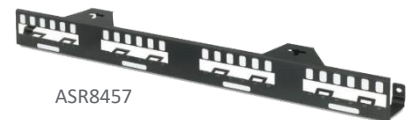

ASR8457



ASR7711

ASR8621



ASR7710



ASR8442

Finger-type Horizontal Cable Managers

Cable managers for patching and crossover applications featuring smooth radius plastic fingers that protect the cable from kinking and binding. Hinged, snap-on covers provide a clean look and retain large cable bundles. These cable managers include hardware for double-sided configurations with two units.

Model	Description
ASR8602A	1U horizontal cable manager with 4 in. (101 mm) fingers and snap-on cover
ASR8600A	2U horizontal cable manager with 4 in. (101 mm) fingers and snap-on cover
ASR8612	1U horizontal cable manager with 6 in. (152 mm) fingers and snap-on cover
ASR8606	2U horizontal cable manager with 6 in. (152 mm) fingers and snap-on cover
ASR8603A	2U horizontal cable manager with 6 in. (152 mm) fingers, snap-on cover, rear cable pass-through holes and slots for ASR8008BLK/ASR8016ABLK horizontal cable channel
ASR8605	3U horizontal cable manager with 6 in. (152 mm) fingers, snap-on cover, rear cable pass-through holes and cable channel slots

Model	Description
ASR8425A	1U horizontal cable manager with four rings
ASR8426A	2U horizontal cable manager with four rings
ASR8428	2U horizontal cable manager with four rings and pass-through holes
ASR8427A	2U horizontal cable manager with multiple rings and small cable retainers
ASR8113A	Cable management rings, 10 pack (5 large, 5 small)
ASR7707	Cable management rings, 8 in. (203 mm) deep for 30 in. (750 mm) wide enclosures (ASR3x5x), 8 pack

Model	Description
ASR8429	1U cable pass-through manager with brush strip
ASR8129	Cable management arm for use with sliding shelves
ASR8008BLK	Horizontal cable side channel, 18 in. (457 mm) to 30 in. (750 mm) adjustment, for routing cable front-to-back between the standard wide rack mounting rails
ASR8016ABLK	Horizontal cable side channel, 10 in. (254 mm) to 18 in. (457 mm) adjustment, for routing cable front-to-back between the standard wide rack mounting rails
ASR7706	Mounting rail brush strips for 30 in. (750 mm) wide enclosures (ASR3x5x), 6 pack



ASR8603A



ASR8605



ASR8606



ASR8425A



ASR8426A



ASR8428



ASR8427A



ASR8113A



ASR7707



ASR8129



ASR8429

Rack enclosures allow you to use a system of troughs and partitions for routing power and data cables across the top.

These troughs and partitions:

- Reduce the need for expensive suspended cable tray systems
- Install toollessly with snap-in tabs and have standard attachment points for cable ladder systems

1. Power cable trough

- Supports power distribution cables
- Provides separation from data cables
- Data cables pass through underneath to front partitioned area

Model	Description
ASR8561	Cable trough, 24 in. (600 mm) enclosures
ASR8571	Cable trough, 30 in. (750 mm) enclosures

2. Solid data cable partition

- Partitions the top of the enclosure into cable routing areas
- Solid face provides clean appearance at the front of the enclosure

Model	Description
ASR8163ABLK	Pass-through data partition, 24 in. (600 mm) enclosures
ASR8173BLK	Pass-through data partition, 30 in. (750 mm) enclosures



ASR8561



ASR8162ABLK



ASR8163ABLK



ASR8186



4. Cable ladders and accessories

- Cable ladders and attachment kits for routing power and data cabling overhead from rack to rack



Model	Description	Model	Ladder Accessories
ASR8164ABLK	Cable ladder, 6 in. (152 mm) (AR8164AKIT 6 in. ladder with attach kit)	AR8461	Ladder corner clamp
ASR8165ABLK	Cable ladder, 12 in. (304 mm) (AR8165AKIT 12 in. ladder with attach kit)	AR8462	Ladder angle clamp
ASR8576	Alternate mounting — ladder to power troughs	AR8463	Ladder stacking
ASR8177BLK	Alternate mounting — ladder to data partitions	AR8465	Ladder wall termination
ASR8168BLK	Ladder to NetShelter SX roof	AR8169	Ladder clamp kit
ASR8186	Ladder elevation bracket	-	-
ASR8460	Ladder to two-post rack	-	-

3. Pass-through data cable partition

- Partitions the top of the enclosure into cable routing areas
- Pass-through hole provides cable access into multiple cable areas

Model	Description
ASR8162ABLK	Solid data partition, 24 in. (600 mm) enclosures
ASR8172BLK	Solid data partition, 30 in. (750 mm) enclosures

Shelving

Fixed and sliding shelves to enable the mounting of tower units, monitors and other equipment.

Model	Description
ASR8105BLK	Fixed shelf, 50 lb. (22 kg)
ASR8122BLK	Fixed shelf, 250 lb. (113 kg)
ASR8123BLK	Sliding shelf, 100 lb. (45 kg)
ASR8128BLK	Sliding shelf, 200 lb. (90 kg)
ASR8422	Double-side fixed shelf for two-post rack
ASR8126ABLK	17 in. (431 mm) sliding keyboard shelf



ASR8105BLK



ASR8122,28BLK



ASR8126ABLK/
ASR8127BLK



ASR8422

Bolt-down and Stabilization

Stabilization plates and hardware to prevent tip over in stand-alone rack applications and meet specific anchoring requirements.

Model	Description
ASR7700	Rack stabilization plate to prevent tipping when sliding out equipment
ASR7701	Rack bolt-down kit, meets IBC seismic requirements for moderate seismic zones
ASR7701-S	Rack bolt-down kit, meets IBC seismic requirements for high seismic zones



ASR7701 and
ASR7701-S



ASR7700



ASR7711



ASR8150BLK

Miscellaneous Mounting Brackets

Variety of mounting brackets for mounting IT equipment.

Model	Description
ASR7711	0U multipurpose accessory mounting bracket for side mounting of 1U/2U products and rack PDUs
ASR8150BLK	23 in. (584 mm) to 19 in. (482 mm) mounting adapter brackets for use with ASR7510 23 in. (584 mm) EIA mounting rails

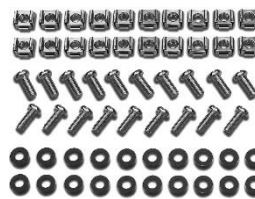

ASR8100

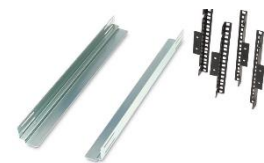

ASR8006A

Hardware Kits

Available for additional hardware to accommodate equipment mounted in varying mounting options.

Model	Description
ASR8100	M6 cage nuts and screws, 32 pack
ASR8400	#12-24 screws, 100 pack
ASR8005	#10-32 cage nuts, 36 pack

Replacement Doors, Side Panels, Roofs

Standard doors, side panels and roofs are available for all enclosure sizes.



Specialty Roofs, Side Panels and Accessories

Model	Description
ASR7252	Networking roof for high density cabling, 30 in. (750 mm) wide x 42 in. (1070 mm) deep
ASR7716	Networking roof for high density cabling, 30 in. (750 mm) wide x 42 in. (1070 mm) deep
ASR7215	NetShelter AV enclosure top mount conduit access adapter
ASR7209	Open roof support bridge for overhead troughs and partitions
ASR7305A	NetShelter SX pass-through side panel, 42U x 42 in. (1070 mm) deep
ASR7313	NetShelter SX pass-through side panel, 42U x 47.5 in. (1200 mm) deep
ASR7315	NetShelter SX pass-through side panel, 45U x 42 in. (1070 mm) deep
ASR7316	NetShelter SX pass-through side panel, 45U x 47.5 in. (1200 mm) deep
ASR7375	NetShelter SX pass-through side panel, 48U x 42 in. (1070 mm) deep
ASR7314	NetShelter SX pass-through side panel, 48U x 47.5 in. (1200 mm) deep
ASR7714	Replacement snap-in brush strips for SX roofs
ASRCF501	Roof fan for 24 in. (600 mm) wide x 42 in. (1070 mm) deep enclosures, 120 Vac
ASRCF502	Roof fan for 24 in. (600 mm) wide x 42 in. (1070 mm) deep enclosures, 208–230 Vac
ASRCF503	Roof fan for 30 in. (750 mm) wide x 42 in. (1070 mm) deep enclosures, 120 Vac
ASRCF504	Roof fan for 30 in. (750 mm) wide x 42 in. (1070 mm) deep enclosures, 208–230 Vac
ASRCF505	Roof fan for NetShelter AV 24 in. (600 mm) wide x 32.5 in. (825 mm) deep, 115 Vac
ASR8132A	Combination lock handle for NetShelter SX enclosures, 2 pack



Mounting Rails

Vertical EIA rail mounting kits for different widths and depths.

Model	Description
ASR7252	Networking roof for high density cabling, 30 in. (750 mm) wide x 42 in. (1070 mm) deep



Recessed Rail Kits

Intermediate mounting rails for supporting shallow-depth equipment.

Model	Description
ASR7252	Networking roof for high density cabling, 30 in. (750 mm) wide x 42 in. (1070 mm) deep
ASR7716	Networking roof for high density cabling, 30 in. (750 mm) wide x 42 in. (1070 mm) deep
ASR7215	NetShelter AV enclosure top mount conduit access adapter
ASR7209	Open roof support bridge for overhead troughs and partitions

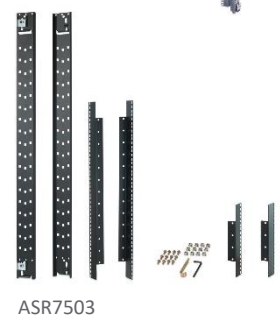

Roof Module for Aisle closing

Light Box

Model	Description
ASR4410	Width: 300 mm
ASR4420	Width: 375 mm
ASR4430	Width: 400 mm
ASR4440	Width: 600 mm



Open Fire Roof Module

Model	Description	Features
ASR4110	Width: 300 mm	Fix Aisle width: 1200 mm
ASR4120	Width: 375 mm	Fix Aisle width: 1500 mm
ASR4130	Width: 400 mm	Fix Aisle width: 1600 mm
ASR4210	Width: 300 mm	Flexible ± 200 mm Aisle width: 800 mm
ASR4220	Width: 375 mm	Flexible ± 200 mm Aisle width: 1000 mm
ASR4230	Width: 400 mm	Flexible ± 200 mm Aisle width: 1200 mm



Tunnel Roof

Model	Description	Features
ASR4310, 11	Width: 300 mm	"L" series - "U" series Aisle width: 1200 mm
ASR4320, 21	Width: 375 mm	"L" series - "U" series Aisle width: 1500 mm
ASR4330, 31	Width: 400 mm	"L" series - "U" series Aisle width: 1600 mm



Blind Aisle Closure Panel

Back panel in painted sheet metal for aisle closing, supplied with screws and fixing brackets.

Model	Description	Features
ASR4510, 11	Aisle width: 800 mm	Height: 42 mm, 47 mm
ASR4520, 21	Aisle width: 1000 mm	Height: 42 mm, 47 mm
ASR4530, 31	Aisle width: 1200 mm	Height: 42 mm, 47 mm
ASR4540, 41	Aisle width: 1500 mm	Height: 42 mm, 47 mm
ASR4550, 51	Aisle width: 1800 mm	Height: 42 mm, 47 mm



Upper Front/Rear Perimeter Closing Panel

Front/rear containment plate for the installation of a 150-mm high polycarbonate roof.

Model	Description	Features
ASR4610	Aisle width: 300 mm	Height: 150 mm
ASR4620	Aisle width: 600 mm	Height: 150 mm
ASR4630	Aisle width: 800 mm	Height: 150 mm



Upper Side Perimeter Closing Panel

Side containment plate for the installation of a 150 mm high polycarbonate roof.

Model	Description	Features
ASR4710	Aisle width: 1000 mm	Height: 150 mm
ASR4720	Aisle width: 1200 mm	Height: 150 mm

Manual Aisle Door

Symmetrical opening of the two doors fixed to a dedicated rail. The doors are opened from the outside using handles, with the possibility of installing a lock with a key. The doors have a safety opening system with unlocking from the inside in case of emergency.

Model	Description	Features
ASR4800, 01	Aisle width: 800 mm	Height: 42 mm, 47 mm
ASR4810, 11	Aisle width: 1000 mm	Height: 42 mm, 47 mm
ASR4820, 21	Aisle width: 1200 mm	Height: 42 mm, 47 mm
ASR4830, 31	Aisle width: 1500 mm	Height: 42 mm, 47 mm
ASR4840, 41	Aisle width: 1800 mm	Height: 42 mm, 47 mm

Automatic Aisle Door

Sliding doors can be supplied with an automatic opening device.

Model	Description	Features
ASR4850, 51	Aisle width: 800 mm	Height: 42 mm, 47 mm
ASR4860, 61	Aisle width: 1000 mm	Height: 42 mm, 47 mm
ASR4870, 71	Aisle width: 1200 mm	Height: 42 mm, 47 mm
ASR4880, 81	Aisle width: 1500 mm	Height: 42 mm, 47 mm
ASR4890, 91	Aisle width: 1800 mm	Height: 42 mm, 47 mm





Modular Power Distribution Unit (PDU)

Features

- Advanced power quality monitoring and metrics, $\pm 1\%$ metering accuracy
- C13 and C19 combined in any order, auto-locked outlets, outlet's power status LED indicate
- Individual outlet control, power sequencing on/off, timed on/off control
- LCD display with touchable screen, LCD orientation rotatable, metering information real-time display
- Ethernet 10M/100M, USB, CAN, I/O, IIC (sensor), RS485 (sensor)
- Protocols: HTTP/HTTPS (HTML5, REST, JSON), SSH, IoT (MQTT), SNMP (V1, 2c, 3), SMTP
- User configurable threshold alarms for sensors reported over SNMP, SMTP, and HTTP POST to customizable URL
- Access control through user accounts with passwords and X.509 (PKI) certificates, Cloud Access (AWS and Google)
- Signed and encrypted firmware upgrades (network, USB) to ensure authenticity and integrity
- Circuit breaker(s) and surge protection,
- Industrial grade mechanical design, Slot assembly mode and screwless on panel
- Temperature, humidity, power consumption monitoring; digital binary state signal sensor; supports third party external sensor with power supply (5V)

The IMP Series PDU is an intelligent modular power distribution with high accuracy energy measurement and reliable outlets controls. It offers industrial-grade reliability, complete power management, user-configurable firmware, and hot-swappable capability for maintenance. Its futureproof design helps manage operations more efficiently and greener.

The IMP series PDU incorporates Center Controller Module, Phase/Total Meter Module, Circuit Breaker Module and Relay/Outlet Module

The Center Controller Module

The intelligent control center of PDU, that houses high compute power, display screen, and multiple connectivity ports.

- LCD with touched display provides information on power usage, outlet status and critical alerts.
- Touchable LCD also provides an easy way to check and control PDU's status on site.

- 10/100 Ethernet ports enable connectivity to network infrastructure, supports protocols with HTTP/HTTPS (HTML5, REST, JSON), SSH, IoT (MQTT), SNMP (V1, 2c, 3) and SMTP with user defined access control to all system functions
- Sensor port allows plug-and-play external sensors of temperature, humidity, Water Leak, Smoke Detector, Door Status Monitor and with threshold exception detection and reporting over the network.
- USB-A update signed and encrypted firmware, USB-B generate diagnostic logs.
- RS485s use to cascade PDUs in daisy mode.

The Phase/Total Meter Module

To meter, monitor energy parameter of every phase or total flow. It can be set on the total input of PDU or be set on the input of any outlets group.

- Voltage (V, TRMS), Current (A, TRMS).
- Active Power (kW), Reactive Power (KVA), Apparent Power (KVA).
- Energy (kWh), Power Factor, Frequency.

The Relay/Outlet Module

A smallest outlet module, one module includes 4 outlets. And the module can meter, monitor and control every outlet within itself, with $\pm 1\%$ metering accuracy following IEC 62053-21 standards. Up to 12 Relay/Outlet modules can be combined into a PDU.

- meter, monitor and control every outlet within module.
- Remote Outlet and Outlet Group On/Of, Outlet Grouping Across Linked PDUs. Identify the exact outlet that caused a circuit breaker to trip.
- Power-on/off Sequencing with Customizable Delays.
- LED Outlet Indicators.
- A rugged and intuitive outlet and power cord locking system plug and unplug easily by auto lock and manual release.

- Alterable Relay Control Technology (ARCT@) greatly reduce energy consuming heating and EMI level, prolong the relays lifetime.

The Circuit Breaker Module

To protect current surge/overload in any unexpected situation.

- Used in AC50Hz/60Hz, rated voltage AC250V equipment circuit.
- Lines to provide accurate and reliable short circuit and overload protection.
- 10,000 ON-OFF operations @6 per minute Endurance.
- Compatible with certifications: UL489, TUV, CCC.
- The status of the module will be displayed in real time on the web side.



In generally, to a typical PDU's configuration, one Center Controller Module and several Relay/Outlet Modules are required, Circuit Breaker Module and Phase/Total Meter Module can be added or not in different configurations.

Specifications

Table 1. Input and output Section Specifications.

Item	Value
Input Plug	Battier Connector
Input Voltage	85-260 VAC
Input Current	32 Amp
Output Receptacles	Nema5-15R, IEC60320-C13, IEC60320-C19, GB2099.9-10A, GB2099.9-16A
Output Nominal Voltage	85-260 VAC
Circuit Breaker	Optional
Communication port	RJ45, 10M/100M, USB, CAN, I/O, IIC (sensor), RS485 (sensor)
Daisy Chain	Up to 255 PDUs can be daisy chained using RS485
Environmental Sensor	Temperature, Humidity, Power Consumption Monitoring, Smoke, Water Leakage Via RJ11 or RJ 45 port Sensor (Supports third party external sensor)
Network Protocol	HTTP/HTTPS (HTML5, REST, JSON), SSH (+PKI), IoT (MQTT), SNMP (v1, 2, 3), SMTP
Energy Monitoring	Voltage (V, RMS), Current (A, RMS), Active Power (kW), Reactive Power(kW), Apparent Power (kVA), Energy (kWh), Power Factor, Frequency Apparent Power (kVA), Energy (kWh), Power Factor, Frequency
Remote Outlet Switching	Yes
Monitoring Input line	Yes
Monitoring Per Group	Yes
Monitoring per Outlet	Yes
Display	2.4" 262K color LCD display: Voltage, current, or active power (per line, per breaker, or per receptacle / outlet); Alarms; Configuration information (name, ratings, IP / Networking information). Auto-flip orientation

Parameter

Table 2. General Specifications.

Measure Parameters	
IRMS Measurement Error	1.0 %
VRMS Measurement Error	1.0 %
Active Energy Measurement Error	0.5 %
Reactive Energy Measurement Error	0.5 %
Power Factor Error	±0.05 Degrees
Relative Humidity Error	±2.0% RH
Temperature Error	±0.3 °C
Other Parameters	
Operating Temperature	-10°C - 60°C
Storage Temperature	-20°C - 70°C
Relative Humidity	10 – 90 % RH, non-condensing
Dimensions (W*D*L)	W: 2.165" (55mm)
	D: 2.362" (60mm)
	L: Base on product configuration
Weight	Base on product configuration

- The length and weight are based on module and outlet configuration; outlet quantity should be multiple of 4.

Ordering Information

This PDU are available with various key features and intelligence levels.

Model no.	Inlet Power Monitoring	Branch Circuit Monitoring	Circuit Breaker Trip Alarming	Outlet Level Monitoring	Outlet Level Switching
ASR 1000 Series	•	•	•	•	•
ASR 2000 Series	•	•	•	-	•
ASR 3000 Series	•	•	•	•	-
ASR 4000 Series	•	•	•	-	-

- Consult your Customer Service Representative or Applications Engineer for special configuration of your application.

Technical Specifications

Features	
Model	ASR5100
Energy Metering	Power (Active/Reactive/Apparent KVA), Voltage (V, TRMS), Current (A, TRMS), Energy (kWh), Power Factor, Frequency
Metering Accuracy	ISO/IEC 62053-21 1%
Metering per Input Line	Yes
Metering per Branch Circuit Breaker	Yes
Metering per Output Receptacle	Yes
Remote Outlet Switching	Yes
Timing/schedule Outlet Switching	Yes
Circuit Breaker status	Yes
Compatible sensors	Temperature, Humidity, Water Leak, Smoke Detector, Door Status Monitor
Alarm	Audible and Visual Alarm output
Networking	10/100 Base-T Ethernet port
Remote Management	HTTP/HTTPS (HTML5, REST, JSON), SSH (+PKI), IoT (MQTT), SNMP(V1,2C,3), SMTP
Cascading	Can be daisy chained together using RS-485
Onboard Display	LCD Touch-screen (orientation rotatable); Meter information (Voltage, Current, Active power and Energy); System information, Network information
Embedded Processor	ARM Cortex M7 480 MHZ, 2MB SPI Flash, 1MB RAM



Technical Specifications

Input	
Input Plug	IEC60309 IP44 32A/415VAC 3P+N+PE Male[3P5W]
Cord Length	3 meters (9.84 feet) standard
Cord Entry	Top feed and Bottom feed compatible
Input Current	32A
Input Voltage	85 – 240V, 3 Phase
Input Frequency	50/60Hz
Power Capacity	21.1kVA at 220V
Output	
Nominal Output Voltage	220V
Rated Output Voltage	85 - 240V
Receptacles [outlets]	IEC60320 C13 Locking, 10A IEC60320 C19 Locking, 16A
Cord Retention	No
Overload Protection	B2T3-16
Physical	
Color	shell: black/gray/champagne, outlet panel: black/Ocean Blue/gray/green/yellow/Light Sky Blue
Unit Dimensions (WxDxH)	2.2" x 2.4" x 68.9" (55mm x 60mm x 1750mm)
Unit Weight	4.9kg
Shipping Weight	6.1 kg
Shipping Dimensions (WxDxH)	6.7" x 4.8" x 77.8" (170mm x 120mm x 1976mm)



Technical Specifications

Environmental		
Operating Temperature	-10°C - 60°C	
Storage Temperature	-20°C - 70°C	
Operating Relative Humidity	85%	
Operating altitude	0-3000m	
Conformance		
Regulatory Approvals	UL, FCC, VDE, RoHS,	
Warranty	2 years	
Accuracy	Input Measurement	Output Measurement
Voltage	±1% at 0.1 V resolution	±1% at 0.1 V resolution
Current	±1% at 0.1 A resolution	±1% at 0.1 A resolution
Active Power	±1% at 1 W resolution	±1% at 1 W resolution
Apparent Power	±1% at 1 VA resolution	±1% at 1 VA resolution
Power Factor	±1% at 0.1 resolution	±1% at 0.1 resolution
Active Energy	±1% at 0.1 kWh resolution	±1% at 0.1 kWh resolution

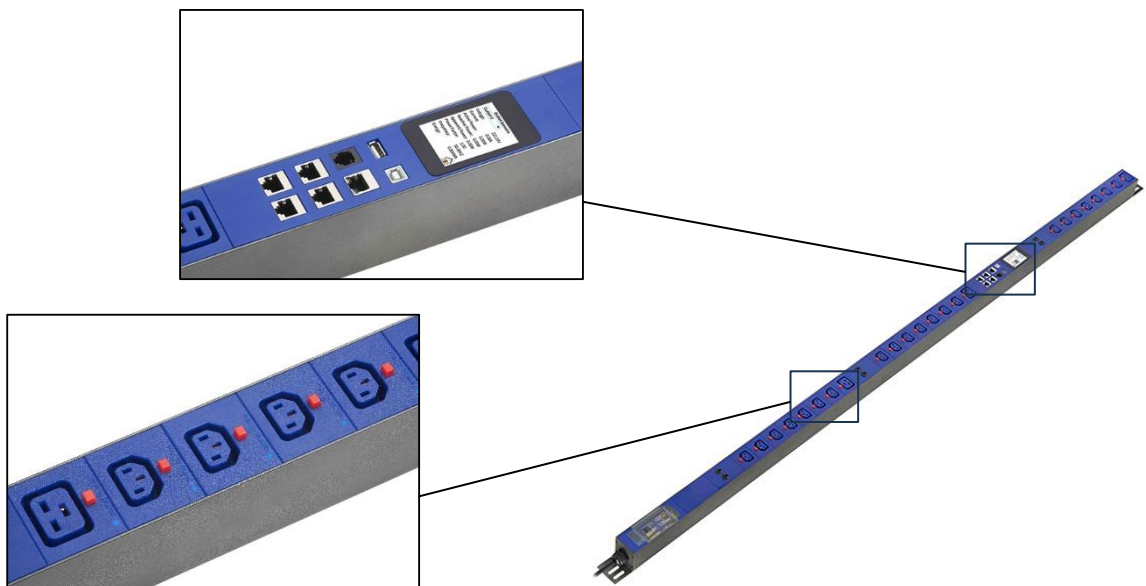

Electrical Diagram

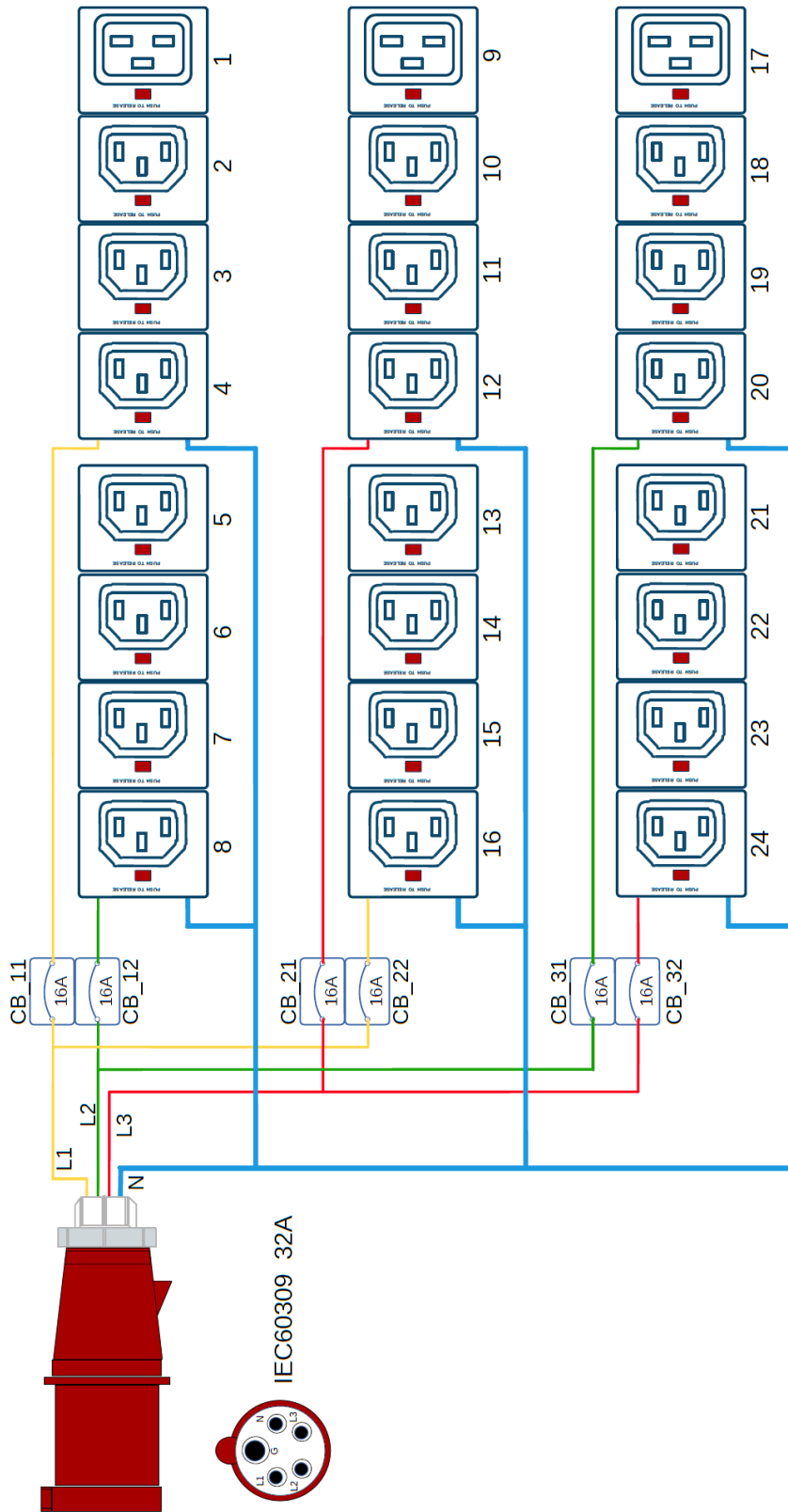



In-Row Cooling System

Direct Expansion (DX) In-Row Cooling Systems

The DX Type In-Row Cooling Machine is a cutting-edge solution designed for precision cooling in data centers and computer rooms. Leveraging advanced Direct Expansion (DX) technology with an Inverter BLDC (Brushless Direct Current) condensing unit, this cooling machine delivers high efficiency, superior temperature and humidity control, and flexible operation. Its innovative design, featuring a variable speed evaporator fan, ensures optimal performance and energy savings, making it an ideal choice for modern data center environments.

Applications:

- Data Centers: Ideal for high-density server environments, ensuring precise and reliable cooling.
- Telecommunications Facilities: Provides consistent cooling for critical telecom infrastructure.
- IT Rooms and Server Farms: Ensures optimal operating conditions for IT equipment, preventing downtime and equipment failure.

Benefits:

- Enhanced Energy Efficiency: Inverter BLDC technology and variable speed fans significantly reduce energy consumption, leading to lower operational costs.
- Superior Temperature and Humidity Control: Maintains stable conditions to protect sensitive IT equipment and ensure peak performance.
- Space Optimization: The In-row design maximizes floor space utilization, crucial for high-density data centers.
- Scalability and Flexibility: Easily scalable to meet evolving data center needs, providing a future-proof cooling solution.
- Reduced Noise Levels: Quieter operation creates a more pleasant working environment in data centers.

Features

Inverter BLDC Condensing Unit:

- **Enhanced Efficiency:** The BLDC condensing unit offers superior energy efficiency and performance compared to traditional systems. Its inverter technology allows for precise control of cooling capacity, so reducing energy consumption achieved.
- **Quiet Operation:** BLDC motors operate more quietly, creating a less disruptive environment in the data center.

Variable Speed Evaporator Fan

- **Energy Savings:** The variable speed fan adjusts its speed based on real-time cooling demands, ensuring efficient airflow and reducing power consumption.
- **Optimal Cooling:** Provides consistent temperature and humidity control, protecting sensitive IT equipment from overheating and humidity-related issues.

Precision Temperature and Humidity Control

- **Stable Environment:** Maintains precise control over temperature and humidity levels, ensuring the optimal operating conditions for data center equipment.
- **Advanced Sensors:** Equipped with high-accuracy sensors for real-time monitoring and adjustments.

Compact In-Row Design

- **Space-Saving:** The In-row configuration fits seamlessly between server racks, maximizing floor space and delivering targeted cooling where it's needed most.
- **Modular and Scalable:** Easy to scale up or down to match the changing cooling requirements of the data center.

Energy-Efficient Operation

- Adaptive Control Algorithms: Advanced control algorithms dynamically adjust cooling output to match the data center's load conditions, optimizing energy use.
- Reduced Operating Costs: Lower energy consumption translates to significant cost savings over time.

Intelligent Monitoring and Control

- Real-Time Data: Continuous monitoring of system performance, temperature, and humidity, with data accessible remotely for proactive management.
- User-Friendly Interface: Intuitive controls and interface for easy operation and configuration.

High Reliability and Redundancy

- Robust Design: Built to withstand the demanding conditions of data center environments, ensuring reliable performance.
- Redundancy Options: Can be integrated with other cooling systems to provide redundancy and ensure continuous operation.

Eco-Friendly Refrigerant

- Sustainability: Uses environmentally friendly refrigerants, contributing to lower global warming potential (GWP) and compliance with environmental regulations.

DX In-Row Cooling Systems Operation Diagram

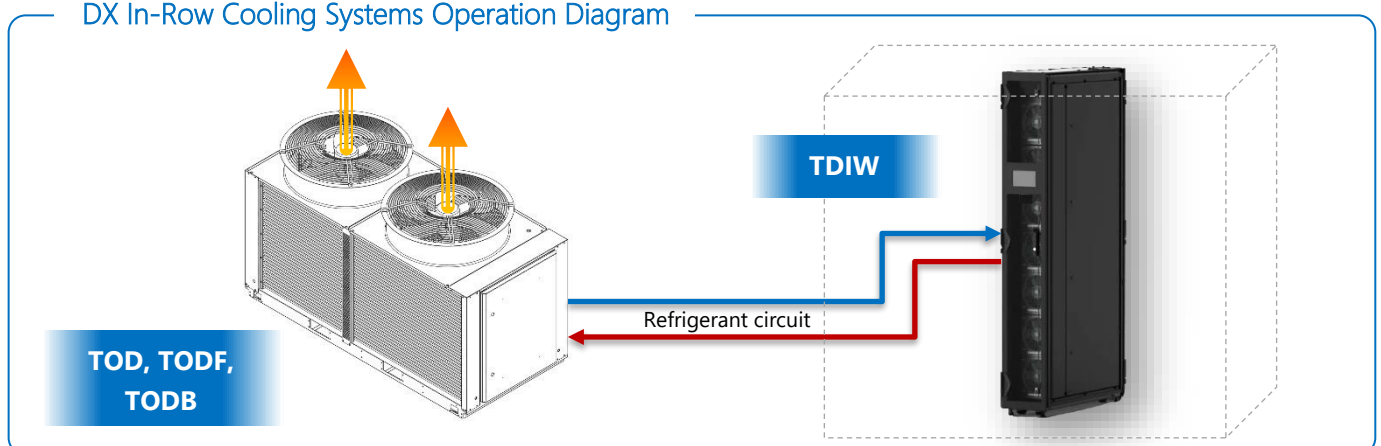

Optional Add-on

1. Multi-Indoor Unit Connection

- **Redundancy and Cost Efficiency:** Multiple indoor in-row units can be connected to a single outdoor unit, providing enhanced redundancy and reducing overall costs. This setup ensures continuous cooling operation even if one unit requires maintenance, offering a reliable and cost-effective solution for data centers.

2. Built-In Humidifier

- **Enhanced Environmental Control:** The system can be ordered with a built-in humidifier, allowing for precise control over humidity levels. This feature helps maintain optimal conditions, protecting sensitive IT equipment from humidity-related issues and ensuring consistent performance.

3. Drain Pump

- **Convenient Drainage:** For installations where gravity drainage is not feasible, the system can be equipped with a built-in drain pump. This option facilitates efficient removal of condensate water, ensuring smooth and hassle-free operation.

Technical Data Table

Model no.			TDIWDF30SSD	TDIWDF60SSD
Cooling capacity	Db 27 °C Wb 23 °C	KW	23	41
	Db 30 °C Wb 23 °C	KW	27	49
	Db 35 °C Wb 26.5 °C	KW	31	54
SHR		-	<0.95	
Input power		KW	3	8
Heating capacity		KW	2	4
Air flow rate		m ³ /h	4200	7400
Fan		Type	Variable speed backward curved plug fan	
Remote monitoring		-	SNMP / Modbus TCP / Modbus RTU / BACnet / CAN-FD	
Refrigerant		Type	R410a	
Expansion Valve		Type	EEV	
Pipe connection	Inlet	mm	3/8"	5/8"
	Outlet	mm	7/8"	1 1/8"
Air filter		Type	G4	
Power supply		-	230 V ±10% – 50 HZ	400 V – 50 Hz Dual Power
Dual power		-	Included	
Dimension	WxHxL	mm	300x2000x1200	600x2000x1200
Net weight		kg	150	250

Chilled Water In-Row Cooling Systems

The Water Chilled Type In-Row Cooling Machine is an advanced cooling solution designed specifically for computer room air conditioning applications. Utilizing chilled water supplied from a central chiller or dry cooler, this in-row cooling machine ensures precise temperature and humidity control while maximizing energy efficiency. The integration of variable speed evaporator fans further enhances its performance, making it an ideal choice for modern data centers and IT environments.

Applications

- Data Centers: Ideal for high-density server environments, ensuring precise and reliable cooling.
- Telecommunications Facilities: Provides consistent cooling for critical telecom infrastructure.
- IT Rooms and Server Farms: Ensures optimal operating conditions for IT equipment, preventing downtime and equipment failure.

Benefits:

- Enhanced Energy Efficiency: Variable speed evaporator fans and chilled water cooling significantly reduce energy consumption, leading to lower operational costs.
- Superior Temperature and Humidity Control: Maintains stable conditions to protect sensitive IT equipment and ensure peak performance.
- Space Optimization: The In-row design maximizes floor space utilization, crucial for high-density data centers.
- Scalability and Flexibility: Easily scalable to meet evolving data center needs, providing a future-proof cooling solution.
- Eco-Friendly Operation: Utilizes chilled water, reducing the reliance on refrigerants and contributing to lower global warming potential.

Features

Chilled Water Cooling

- **Efficient Heat Removal:** Uses chilled water from a central chiller or dry cooler to efficiently remove heat from the data center environment.
- **Eco-Friendly:** Reduces reliance on refrigerants, offering a more environmentally friendly cooling solution.

Variable Speed Evaporator Fan

- **Maximized Efficiency:** Adjusts fan speed based on real-time cooling demands, optimizing airflow and reducing power consumption.
- **Enhanced Control:** Provides precise temperature and humidity regulation, ensuring optimal conditions for IT equipment.

Compact In-Row Design

- **Space-Saving:** Fits seamlessly between server racks, maximizing floor space and delivering targeted cooling directly to heat-generating equipment.
- **Scalability:** Easily scalable to meet the growing cooling needs of expanding data centers.

Intelligent Monitoring and Control

- **Real-Time Data:** Continuous monitoring of temperature, humidity, and system performance with remote management capabilities.
- **User-Friendly Interface:** Intuitive controls and interface for easy operation and configuration.

Energy-Efficient Operation

- Adaptive Control Algorithms: Dynamically adjusts cooling output to match the data center's load conditions, ensuring energy-efficient operation.
- Reduced Operating Costs: Lower energy consumption leads to significant cost savings over time.

High Reliability and Redundancy

- Robust Design: Built to withstand demanding data center environments, ensuring reliable and continuous operation.
- Redundancy Options: Can be integrated with other cooling systems to provide redundancy and ensure uninterrupted cooling.

Water Chilled In-Row Cooling Systems Operation Diagram

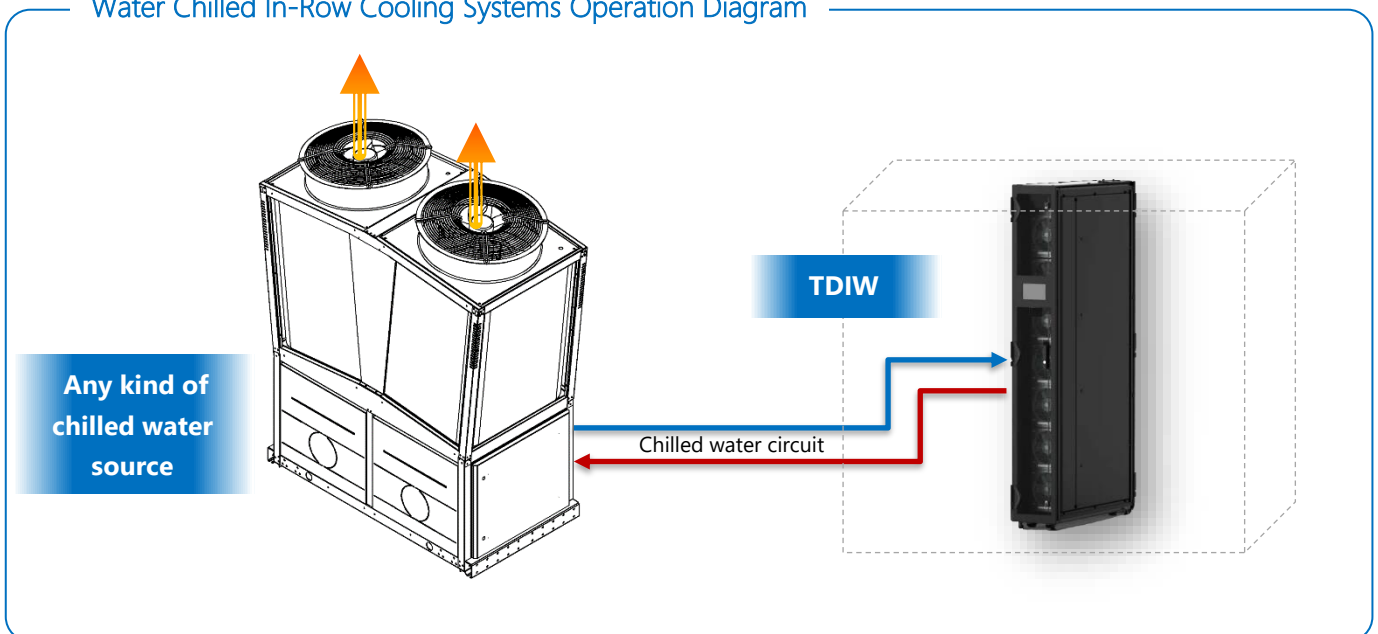

Optional Add-on

1. Dew Point Control Kit

- **Maximized Sensible Heat Removal:** This kit includes a PWM controlled variable speed pump that adjusts the flow in the coil, optimizing dew point control for maximum sensible heat removal without latent heat removal. This ensures efficient cooling and enhanced environmental control.

2. Built-In Humidifier

- **Enhanced Environmental Control:** The system can be ordered with a built-in humidifier, providing precise humidity control to maintain optimal conditions and protect sensitive IT equipment from humidity-related issues.

3. Drain Pump Options

- **Standard Drain Pump:** Ensures efficient removal of condensate water, suitable for installations where gravity drainage is not feasible.
- **Dual Drain Pump:** Offers extra redundancy with dual drain pumps, ensuring continuous and reliable condensate removal for uninterrupted operation.

Technical Data Table

Model no.			TDIWLWA/B30SDD	TDIWLWA/B60SDD
Cooling capacity	Db 27 °C Wb 23 °C	KW	23	41
	Db 30 °C Wb 23 °C	KW	27	49
	Db 35 °C Wb 26.5 °C	KW	31	54
SHR		-	<0.95	
Input power		KW	3	8
Heating capacity		KW	2	4
Air flow rate		m ³ /h	4200	7400
Fan		Type	Variable speed backward curved plug fan	
Remote monitoring		-	SNMP / Modbus TCP / Modbus RTU / BACnet / CAN-FD	
Coolant		Type	Water / Water-Glycol 30%	
Water flow rate	max	m ³ /h	5.5	12
Pipe connection	Inlet	mm	1 1/4"	2"
	Outlet	mm	1 1/4"	2"
Air filter		Type	G4	
Power supply		-	230 V ±10% – 50 HZ	400 V – 50 Hz Dual Power
Dual power		-	Included	
Dimension	WxHxL	mm	300x2000x1200	600x2000x1200
Net weight		kg	150	250

Hybrid In-Row Cooling Systems

The Hybrid In-Row Cooling Machine is an advanced and versatile solution designed to meet the dynamic cooling needs of modern data centers. This innovative product seamlessly integrates with computer room air conditioning systems to ensure optimal temperature control, enhanced energy efficiency, and reliable performance. The hybrid design allows it to utilize both Direct Expansion (DX) and chilled water as sources for cooling, offering unparalleled flexibility and adaptability to varying cooling demands and infrastructure setups.

Applications:

- Data Centers: Optimized for high-density server environments, ensuring consistent cooling performance even under peak load conditions.
- Telecom Facilities: Provides reliable cooling for critical telecommunication infrastructure, ensuring uninterrupted service.
- Edge Computing Sites: Ideal for remote or small-scale data centers where space and resources are limited.

Features

- Dual Cooling Sources

- DX Cooling: Utilizes refrigerant to directly cool the Heat Exchanger. Ideal for environments where chilled water is not readily available or where direct cooling is more efficient.
- Chilled Water Cooling: Uses a chilled water loop, leveraging existing chilled water infrastructure for efficient heat removal. Perfect for large-scale data centers with established water-cooled systems.
- DX Cooling + Water Cooling: Benefits of Simultaneous DX Cooling + Water-Free Cooling;

Enhanced Efficiency

Combining DX and chilled water cooling optimizes energy use, leading to significant energy savings and lower operational costs.

Increased Reliability

Redundant cooling paths ensure continuous operation even if one system experiences issues.

Operational Flexibility

The ability to dynamically switch between cooling methods allows for adaptability to changing conditions and load demands.

Cost-Effective Maintenance

The ability to perform maintenance on one system without shutting down the cooling ensures continuous protection of critical IT equipment.

In summary, the simultaneous use of DX and water-free cooling in the Hybrid In-Row Cooling Machine provides a robust, efficient, and flexible solution for data center cooling, ensuring optimal performance and reliability.

- DX Cooling + Free Cooling: Free cooling, also known as economizer cooling, leverages the cooler outdoor air during winter months to assist in cooling data center environments. When integrated with a DX (Direct Expansion) cooling system in the Hybrid In-Row Cooling Machine, it offers several significant benefits:

Energy Savings

- Reduced Compressor Usage: During winter, the need for mechanical refrigeration is minimized because the colder outdoor air can be used to cool the data center. This reduces the runtime of compressors in the DX system, leading to substantial energy savings.
- Lower Power Consumption: By utilizing free cooling, the overall power consumption of the cooling system decreases, resulting in lower energy bills and improved energy efficiency.

Extended Equipment Life

- Reduced Wear and Tear: With less reliance on compressors and other mechanical components during cooler months, the wear and tear on the DX system is reduced. This can extend the lifespan of the cooling equipment, lowering maintenance costs and increasing reliability.

- **Balanced Load Distribution:** By alternating between free cooling and DX cooling, the load is more evenly distributed, reducing the strain on any single system.

Enhanced Cooling Efficiency

- **Optimal Use of Resources:** The system can intelligently switch between free cooling and DX cooling based on real-time temperature and load conditions, ensuring that the most efficient cooling method is used at all times.
- **Higher Cooling Capacity:** The combination of free cooling and DX cooling can handle higher cooling loads more effectively, ensuring that the data center maintains optimal temperatures even during peak operation.

Environmental Benefits

- **Reduced Carbon Footprint:** Utilizing free cooling reduces the need for energy-intensive mechanical cooling, lowering the data center's overall carbon footprint. This contributes to sustainability goals and can enhance the company's environmental credentials.
- **Sustainable Operations:** By maximizing the use of natural cooling resources, data centers can operate in a more environmentally friendly manner, supporting green initiatives.

Cost Saving

- **Lower Operational Costs:** Reduced energy consumption directly translates to lower operational costs. Free cooling can significantly decrease the cooling costs during winter months, providing financial benefits to the data center operations.
- **Deferred Capital Expenditure:** The extended lifespan of the cooling equipment due to reduced mechanical stress can defer the need for capital expenditure on replacement or upgrades.

Improved Redundancy and Reliability

- Backup Cooling Option: Free cooling acts as an additional cooling method that can provide backup in case the DX system experiences a failure or requires maintenance.
- Consistent Performance: By incorporating multiple cooling methods, the system ensures consistent and reliable cooling performance, critical for maintaining the uptime and stability of data center operations.

Regulatory and Compliance Benefits

- Energy Efficiency Standards: Many regions have regulations and standards aimed at improving energy efficiency in data centers. Utilizing free cooling can help data centers meet these standards and potentially qualify for energy efficiency incentives or rebates.
- Compliance with Environmental Regulations: Reducing the reliance on mechanical cooling can help data centers comply with environmental regulations aimed at reducing energy consumption and greenhouse gas emissions.

Scalability and Flexibility

- Designed to integrate seamlessly between server racks, the in-row configuration provides targeted cooling directly at the source of heat generation. This modularity allows for scalable expansion as data center needs grow.

Energy Efficiency

- Advanced control algorithms optimize the use of DX and chilled water systems Simultaneously, to maximize energy efficiency. By dynamically switching between cooling modes based on real-time load conditions, the hybrid system minimizes energy consumption and reduces operational costs.

High Precision Cooling

- Equipped with precise temperature and humidity control, the Hybrid In-Row Cooling Machine ensures stable conditions, safeguarding critical IT equipment from overheating and maintaining optimal performance.

Smart Monitoring and Control

- Integrated with intelligent monitoring systems, the cooling machine provides real-time data on temperature, humidity, and system performance. Remote management capabilities allow for proactive maintenance and quick response to potential issues.

Compact and Space-Saving Design

- The in-row configuration maximizes floor space utilization by fitting directly within server aisles. This design minimizes airflow obstructions and enhances cooling efficiency compared to traditional perimeter cooling solutions.

- Multi Cooling Sources

- DX Cooling: Uses refrigerant for direct air cooling.
- Chilled Water Cooling: Utilizes chilled water loops for efficient heat removal.
- Free-cooling with Dry Cooler: Uses Cooling Water From water sources such as cooling towers in summer or closed-circuit dry cooler in winter.

Energy-Efficient Operation

- Dynamic Switching: Automatically switches between DX and chilled water cooling based on real-time conditions to optimize energy use.

Compact In-Row Design

- Space-Saving: Fits between server racks, maximizing floor space and providing targeted cooling.
- Intelligent Monitoring and Control:
- Real-Time Data: Provides continuous monitoring of temperature, humidity, and system performance with remote management capabilities. Using Protocols Such as SNMP, Modbus TCP or Modbus RTU

Enhanced Redundancy

- Backup Cooling: Ensures continuous operation by having dual cooling sources, providing redundancy in case of system failures and reduces the need for having a redundant unit.

Advanced Control Algorithms

- Optimal Performance: Utilizes advanced algorithms to manage cooling modes and improve efficiency in both full load operation and part load operation.

Free Cooling Integration

- Winter Optimization: Leverages cooler outdoor air during winter to reduce energy consumption and enhance cooling power efficiency.

Precise Temperature and Humidity Control

- Stable Environment: Maintains consistent conditions to protect sensitive IT equipment from overheating.

Reduced Maintenance Costs

- Lower Wear and Tear: By distributing the load between DX and chilled water systems, maintenance requirements and costs are minimized.

Hybrid In-Row Cooling Systems Operation Diagram

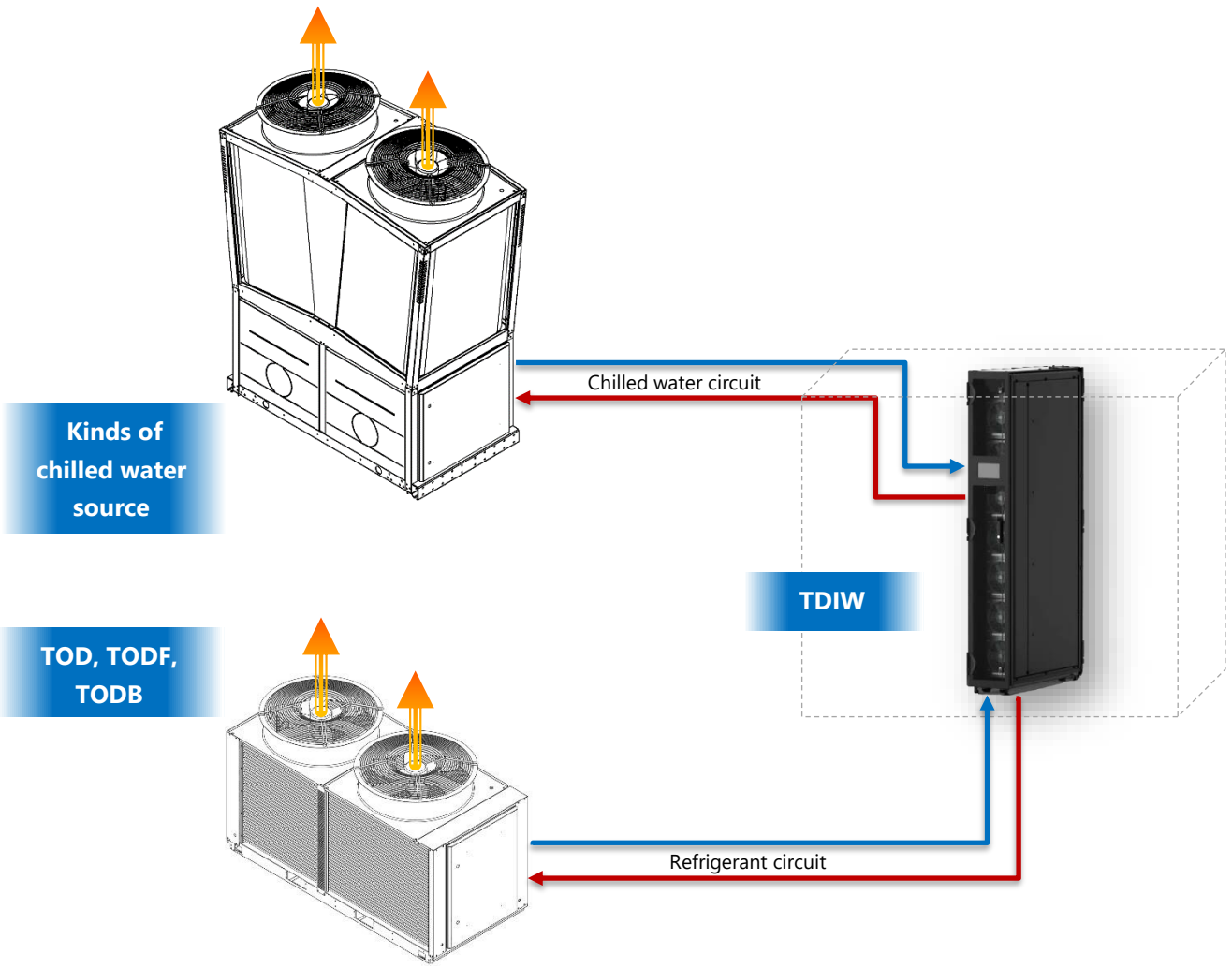

Technical Data Table

Model no.			TDIWHN30SDD	TDIWHN60SDD	
Cooling capacity	Db 27 °C Wb 23 °C	KW	23	42	
	Db 30 °C Wb 23 °C	KW	27	51	
	Db 35 °C Wb 26.5 °C	KW	31	58	
SHR		-	<0.95		
Input power		KW	6	9	
Heating capacity		KW	2	4	
Air flow rate		m ³ /h	4200	7400	
Fan		Type	Variable speed backward curved plug fan		
Remote monitoring		-	SNMP / Modbus TCP / Modbus RTU / BACnet / CAN-FD		
Coolant	DX coil	Type	R410a		
	Primary circuit	Type	FroGen 30 (30% water 70% Glycol)		
	Water coil	Type	Water / Water-Glycol 30%		
Expansion Valve		Type	EEV		
Water flow rate	max	m ³ /h	7.5	15	
Cooling water supply temp range		°C	5 – 15		
Cooling water return temp range		°C	10 – 20		
Cooling water side pressure drop		kPa	22	28	
Pipe connection	DX coil	Inlet	mm	3/8"	5/8"
		Outlet	mm	7/8"	1 1/8"
	Water coil	Inlet	mm	1 1/4"	2"
		Outlet	mm	1 1/4"	2"
Air filter		Type	G4		
Power supply		-	230 V ±10% – 50 HZ 1 Ph + PE	400 V – 50 Hz 3 Ph + N + PE	
Dual power		-	Included		
Dimension	WxHxL	mm	300x2000x1200	600x2000x1200	
Net weight		kg	300	450	



In-Room Cooling System

Benefit

- Extended chilled water coil to deliver high specific cooling capacity with maximum efficiency in limited footprint
- Design based on economization with direct and indirect free-cooling operation
- Smart airflow and thermal load management for energy efficiency
- Highest reliability to safeguard business
- Modular and tailored configuration for many applications
- User friendly touch screen display for easy access to all parameters
- Easy maintenance and full-frontal access

Boosted capacity to save white space occupancy

While data center loads are increasing, there is less space available for cooling equipment that must therefore provide the required cooling capacity with a minimum white space occupancy.

The TDCC series is designed to provide the highest cooling capacity in the linear occupancy compared with traditional units. This means:

- Maximum space available for the IT equipment
- Resized electrical infrastructure



* Traditional design units with fans inside unit cabinet

Large chilled water coil and high specific capacity

TDCC fans are located underneath the floor, enabling more coil surface in the unit and less internal air-side pressure drop.

More heat exchanger coil and less pressure drop equals less power consumption and more capacity inside a compact footprint.

Water circuits design is optimized to have low water pressure drop even with high water flow rate and tight water DT.

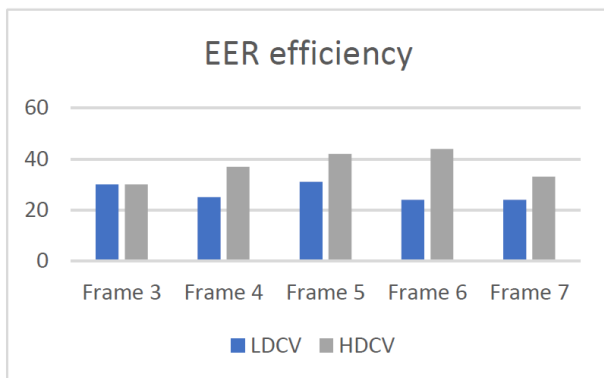
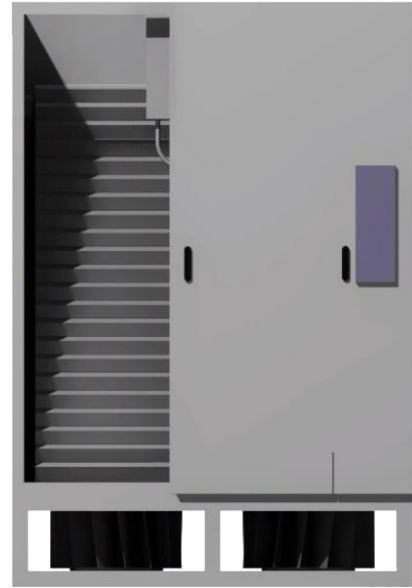

Figure 1. Comparison LDCV*-HDCV -same capacity -Air 35°C/30% -Water 16-24°C

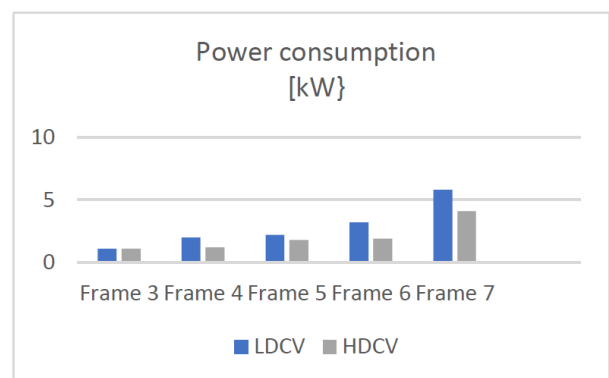

Figure 2. Comparison LDCV*-HDCV -same capacity -Air 35°C/30% -Water 16-24°C

Direct free cooling

Under certain climate and air quality conditions, the optional Free Cooling plenum enables the direct use of external air to cool the Data Center with enormous energy savings.

According to the site conditions the unit can be configured with specific free-cooling control logics to maximize the free cooling hours.

Room humidity is continuously monitored with the ability to disable free cooling in case of high room humidity. maximum and minimum humidity levels are monitored.

Indirect free cooling

When combined with a free-cooling chiller, chilled water systems can leverage on the outdoor temperature to reduce the energy consumption throughout the year. In this case the free cooling effect is provided by the free-cooling coils of chillers.

If properly designed, this system can provide outstanding energy savings and can be applied regardless the outdoor air quality and humidity.

Indirect free cooling and design on optimum temperatures

To further maximize energy efficiency, the TDCC series is available in a High Temperature version (20-250kW).

- Designed to maximize the efficiency of the thermal exchange and provide precise supply air temperature to the servers.
- Optimized for a water regime of 20 °C / 30 °C, with airflow of 37 °C on the return side and a supply air temperature between 24 - 25 °C.
- Wide water DT to reduce water speed in the coil and improve thermal exchange efficiency.

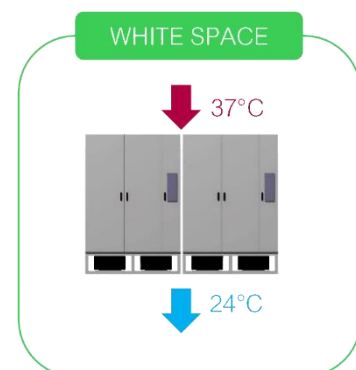

Smart airflow management

The Data Center is a dynamic working environment where required airflow can fluctuate considerably. If this is not correctly considered the cooling system will use more cold air than the actually needed. TDCC units manage the airflow to adjust the cooling system power consumption according to changes in IT load.

Cooling capacity regulation with fixed or variable airflow

Latest Generation composite EC & VFD Fans provide fan speed adjustment via the microprocessor control while the unit is running with the ability to regulate airflow depending on the actual thermal load. This means lower power consumption on the fan side and high part-load efficiency.



Automatic Floor Pressurization System

Fan speed changes to maintain a constant set point of pressure under the raised floor. The change in airflow is based on the pressure differential between the air under the floor and the air above the floor. Automatic Floor Pressurization System (AFPS) adapts the power consumption to IT Room load changes over the time, minimizing energy consumption in all operating conditions.

Active stand-by management

Up to 15 units can be linked to each other through the local LAN network to perform grouping logic. Units are rotated on a time basis to optimize operation. The stand by units integrated with AFPS can be switched on to maximize system efficiency.

Easy maintenance

Ease of maintenance is key to reduce operating costs and avoiding downtime.



Regular maintenance can be carried out while the unit is in operation and without airflow disruption. Full frontal access for regular maintenance. Easy maintenance and component replacement. User friendly electrical connections. The front panels can be opened without the need for special tools. Easy removal of fans from front of the unit.

Continuous availability: dual power source

TDCC units are available in single and dual power supply with automatic electromechanical change over for complete redundancy without single point of failure, as Per TIER recommendations.

The ultracapacitor is included in the dual power supply version and is optional in the single power supply version. It keeps the microprocessor powered during the switching of the lines to save time for reboot of hardware and firmware and allow a quick restart.

High redundancy: dual cooling source

TDCC units are available in Dual Coil (DC) version. These units have two separate hydraulic circuits that can be connected to separate cooling sources, providing redundancy and an emergency cooling source.

Different cooling strategies (tandem, redundant, dual input, single input) allow HXCV DC units to maximize the cooling capacity per linear occupancy.

Cybersecure your data

ABRA HVAC protects customer's security and privacy. TDCC units ensure:

protection against cyber-attacks according to latest standards (TLS 1.2).

the possibility to implement the unit in networks requiring HTTPS certificate.

a three-tier user access with trusted password management.

Continuous monitoring and WEB integration

Metering and continuous monitoring of the operating parameters are key for a precise control of the cooling system operation to prevent system failures.

TDCC units can measure operating conditions as well as cooling capacity and power consumption.

All data can be easily shared with any building management System as units come with a complete set of integrated cards that ensure wide and secure connectivity.

Advanced Control

Advanced control logics ensure an intelligent operation of TDCC units to meet the cooling and airflow needs without wasting energy. Air flow control adapts to specific data center air distribution strategies (hot or cold aisle) and ensures efficient air flow management.

Advanced microprocessor control system UG50 enables direct communication between multiple TDCC units enabling precise cooling.



7 inch

Touch Screen Color LCD

TDCC series main features

1. Coil module

- For installation above the raised floor.
- Large surface copper and aluminum cooling coil.
- Designed for mid-low water temperatures and HT version for high water temperatures (20°C up to 32°C).
- Internal aeraulic layout designed to optimize airflow and maximize fan efficiency

2. Air filters

- High efficiency EU4 or EU5.
- Surface maximization for low air pressure drops

3. Integrated user interface

- 7" touchscreen display.
- Native integration with ECOSTRUXURE IT Platform via SNMP

4. Power supply

- Single and double power supply.
- Ultracapacitor

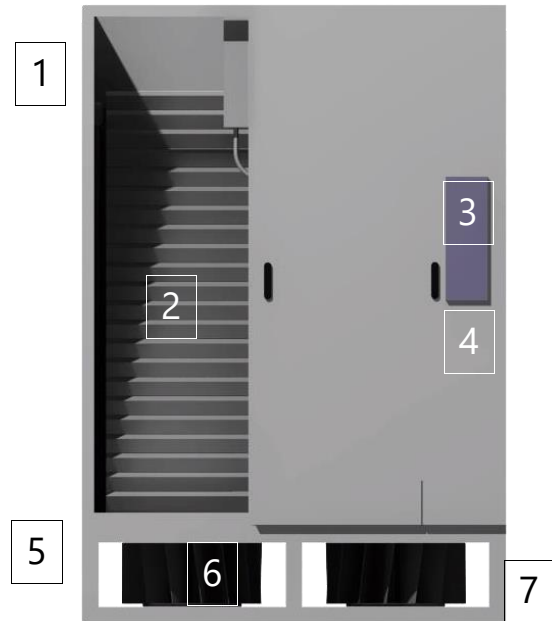

5. Underfloor fan module

- Optimum air distribution.
- Avoid turbulence to increase fan efficiency

6. Electronically Commuted Fans

- Latest generation Radical composite EC & VFD fans.
- New impeller design maximizing efficiency.
- Microprocessor continuous fan speed regulation

7. Adjustable legs

- Easier installation on raised floor

A wide choice of air flow configurations for any site layout

- Fan module open on all sides
- Fan module with frontal air discharge
- Fan module with frontal and lateral air discharge
- Fan module with all sides closed for installation above the floor
- Back discharge for installations in technical corridors out of the IT space

Technical Data Table

DX VERSION										
TDCCD MODEL		F34SSD	F54SSD	F78SSD	F86SSD	F99SSD	F136SSD	F156SSD	F173SSD	F181SSD
Fan type	-	VFD & EC								
Power supply	V/Ph/Hz	400/3/50								
Number of fan	-	1	1	2	2	2	3	3	4	4
Airflow	m ³ /h	10000	13000	19000	24000	24000	31000	35000	40000	42000
Net sensible cooling capacity	KW	34	54	78	86	99	136	156	173	181
DIMENSIONS										
Height	mm	2510								
Length	mm	1010	1310	1720	2170	2170	2570	3100	3100	3405
Depth	mm	865								
ODU DIMENSIONS										
Height	mm	2000					2205			
Length	mm	860					1100			
Depth	mm	2200								

CHILLED WATER VERSION									
TDCCCLW MODEL		A28SDD	A42SDD	A57SDD	A82SDD	A108SDD	A125SDD	A151SDD	
Fan type	-	VFD & EC							
Power supply	V/Ph/Hz	400/3/50							
Number of fan	-	1	1	2	2	3	4	4	
Airflow	m ³ /h	7900	13000	17500	24000	32000	35000	42000	
Net sensible cooling capacity	KW	28	42	57	82	108	125	151	
DIMENSIONS									
Height	mm	2510							
Length	mm	1010	1310	1720	2170	2570	3100	3405	
Depth	mm	865							

1 - Data refer to nominal conditions: Room at 35 °C - 30% RH water temperature 18/24 °C, fan module installed under a 900 mm raised floor, and glycol 10%.

2 - Includes fan module.

3 - Cooling performance refers to one running CW circuit.

4 - Data refer to nominal conditions: Room at 36 °C - 30% RH water temperature 20/30 °C, fan module installed under a 900 mm raised floor, and glycol 20%.

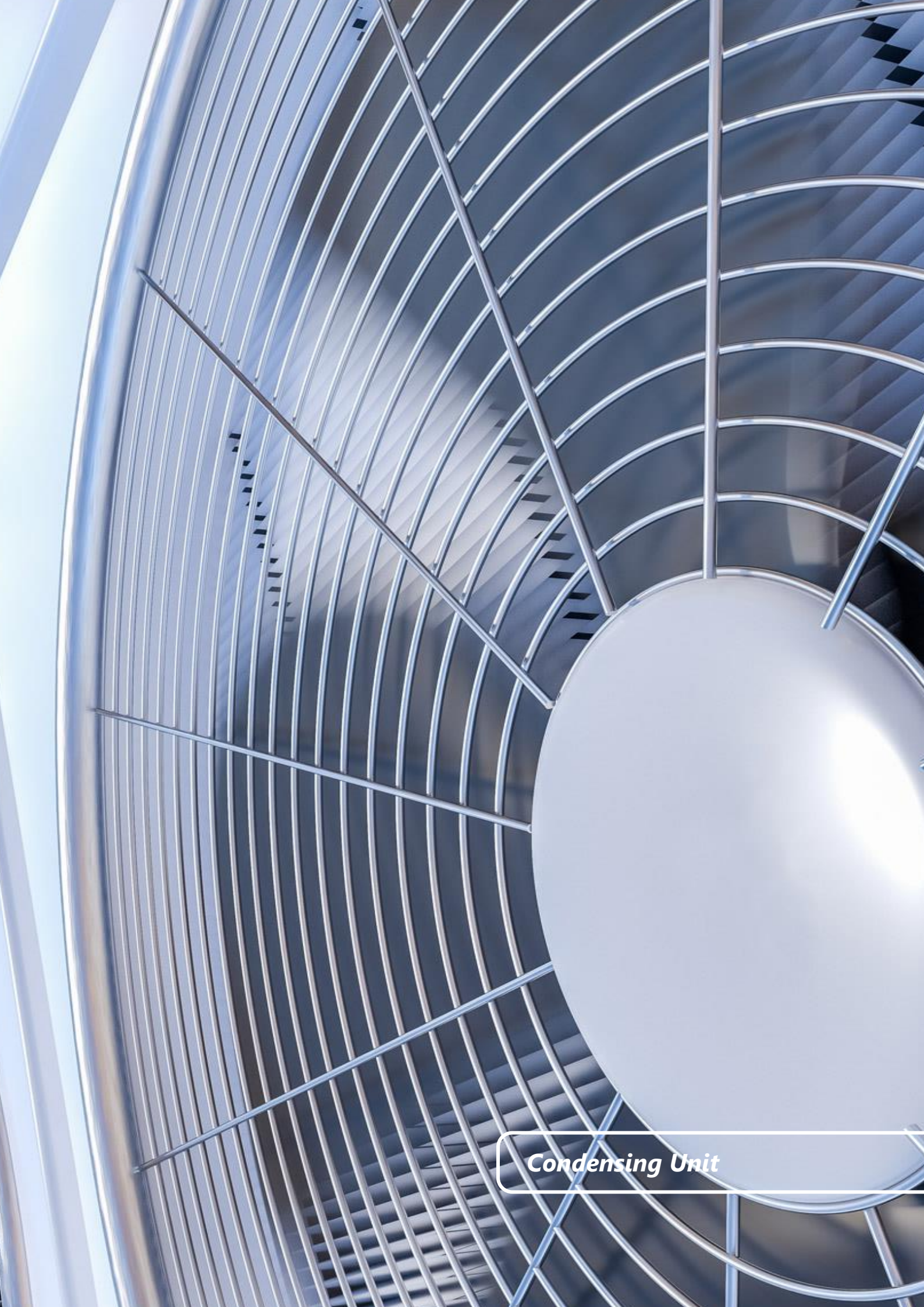

Condensing Unit

DC Brushless Scroll Technology Condensing Units

The DC Brushless Scroll Technology Condensing Units are designed to deliver exceptional reliability and efficiency for data center cooling applications. Available in two models, 45 kW and 90 kW, these condensing units feature variable speed operation, allowing them to seamlessly adjust to a wide range of cooling demands. Their advanced technology and robust design make them ideal for ensuring optimal performance in critical environments.

Applications

- Data Centers: Ensures reliable and efficient cooling for high-density server environments.
- Telecommunications Facilities: Provides consistent and effective cooling for critical telecom infrastructure.
- IT Rooms and Server Farms: Maintains optimal operating conditions for sensitive IT equipment, preventing downtime and equipment failure.

Benefits

- Enhanced Energy Efficiency: Variable speed operation and DC brushless scroll technology significantly reduce energy consumption, leading to lower operational costs.
- Superior Reliability: High-performance compressors and robust design ensure continuous and reliable operation, even in demanding conditions.
- Flexible and Scalable: Suitable for a range of cooling capacities, easily scalable to meet the growing demands of data centers.
- Optimal Environmental Control: Additional options like the dew point control kit and built-in humidifier provide precise control over temperature and humidity.

Features

- DC Brushless Scroll Technology Compressor:
- High Reliability: The DC brushless scroll technology compressor provides outstanding reliability, ensuring continuous operation and minimizing downtime.
- Energy Efficiency: Offers superior energy efficiency, reducing operational costs and contributing to a more sustainable cooling solution.
- Variable Speed Operation:
- Flexible Capacity: The 45 KW model supports indoor units ranging from 25 KW to 45 kW, while the 90 KW model can handle up to 90 KW. This flexibility ensures the units can meet varying cooling demands efficiently.
- Wide Range Operation: The first model operates over a wide range of 6.8 kW up to 45 KW, adapting to different load conditions and maintaining performance even in high ambient temperatures. This ensures continuous operation for crucial applications.
- Scalability and Redundancy:
- Multi-Unit Connection: One outdoor unit can support two indoor units, providing a scalable solution for growing data centers.
- Interlaced Redundancy: Two indoor units can be connected to two outdoor units in an interlaced configuration, maximizing redundancy and ensuring uninterrupted cooling performance.
- High Ambient Temperature Operation:
- Continuous Performance: In high ambient temperatures, the unit adjusts its operation based on the capacity that the condenser allows, ensuring it continues to function without shutting down. This is critical for maintaining cooling in demanding conditions.

Models and Specifications

45 KW Model

- Cooling Capacity Range: 6.8 KW to 45 KW
- Application Range: Ideal for medium-sized data centers, providing flexible and efficient cooling solutions
- Redundancy and Scalability: Can connect with one or two indoor units, offering robust performance

90 KW Model

- Cooling Capacity Range: Up to 90 KW
- Application Range: Suited for larger data centers with higher cooling demands.
- Enhanced Redundancy: Capable of interlaced connection with two outdoor units, ensuring maximum uptime and reliability.

Technical Data Table

Model no.			TODDF45C1	TODDF90C2
Cooling capacity	AHRI-540 (min - max)	KW	6.8 - 45.7	6.8 - 91.4
	EN-12900 (min - max)	KW	6.4 - 43	6.4 - 86
Input power	min-max	KW	1.9 - 16.7	8 - 33.4
Air flow rate		m ³ /h	22000	44000
Fan		Type	Variable Speed Axial EC Fan	
Remote monitoring		-	SNMP / Modbus TCP / Modbus RTU / BACnet	
Refrigerant		Type	R410a	
Pipe connection	Inlet	mm	5/8"	7/8"
	Outlet	mm	1 1/8"	1 3/8"
Power supply		-	400 V - 50 Hz - 3 Ph + N + PE	
Dimension	WxHxL	mm	860x1700x990	860x1700x1980
Net weight		kg	250	500

DC Brushless Scroll Technology Air Cooled Chiller Units

The DC Brushless Scroll Technology Chillers are designed to deliver exceptional reliability and efficiency for data center cooling applications. Available in two models, 40 kW and 80 kW, these Chillers feature variable speed operation, allowing them to seamlessly adjust to a wide range of cooling demands. Their advanced technology and robust design make them ideal for ensuring optimal performance in critical environments.

Applications

- Data Centers: Ensures reliable and efficient cooling for high-density server environments.
- Telecommunications Facilities: Provides consistent and effective cooling for critical telecom infrastructure.
- IT Rooms and Server Farms: Maintains optimal operating conditions for sensitive IT equipment, preventing downtime and equipment failure.

Benefits

- Enhanced Energy Efficiency: Variable speed operation and DC brushless scroll technology significantly reduce energy consumption, leading to lower operational costs.
- Superior Reliability: High-performance compressors and robust design ensure continuous and reliable operation, even in demanding conditions.
- Flexible and Scalable: Suitable for a range of cooling capacities, easily scalable to meet the growing demands of data centers.
- Optimal Environmental Control: Additional options like the dew point control kit and built-in humidifier provide precise control over temperature and humidity.

Features

- DC Brushless Scroll Technology Compressor:
- High Reliability: The DC brushless scroll technology compressor provides outstanding reliability, ensuring continuous operation and minimizing downtime.
- Energy Efficiency: Offers superior energy efficiency, reducing operational costs and contributing to a more sustainable cooling solution.
- Free cooling coil to increase efficiency and cold seasons energy usage
- Adiabatic cooling is a process used to enhance the efficiency of condensers, this method involves pre-cooling the air entering the condenser through the evaporation of water, which significantly lowers the air temperature before it reaches the heat exchanger and reduce the energy consumption and increase reliability of operation.
- Variable Speed Operation:
- Flexible Capacity: The 40 KW model supports indoor units ranging from 25 KW to 40 kW, while the 80 KW model can handle up to 80 KW. This flexibility ensures the units can meet varying cooling demands efficiently.
- Wide Range Operation: The first model operates over a wide range of 6.2 kW up to 40 KW, adapting to different load conditions and maintaining performance even in high ambient temperatures. This ensures continuous operation for crucial applications.
- Scalability and Redundancy:
- Multi-Unit Connection: One outdoor unit can support two indoor units, providing a scalable solution for growing data centers.
- Interlaced Redundancy: Two indoor units can be connected to two outdoor units in an interlaced configuration, maximizing redundancy and ensuring uninterrupted cooling performance.
- High Ambient Temperature Operation
- Continuous Performance: In high ambient temperatures, the unit adjusts its operation based on the capacity that the condenser allows, ensuring it continues to function without shutting down. This is critical for maintaining cooling in demanding conditions.

Models and Specifications

40 KW Model

- Cooling Capacity Range: 6.2 KW to 40 KW
- Application Range: Ideal for medium-sized data centers, providing flexible and efficient cooling solutions
- With optional pump and hydronic section available to order (for selection and sizing refer to hydronics catalogue)
- Free cooling can be ordered as option
- Adiabatic cooling can be ordered as option
- Redundancy and Scalability: Can connect with one or two indoor units, offering robust performance

80 KW Model

- Cooling Capacity Range: Up to 80 KW
- Application Range: Suited for larger data centers with higher cooling demands.
- With optional pump and hydronic section available to order (for selection and sizing refer to hydronics catalogue)
- Free cooling can be ordered as option
- Adiabatic cooling can be ordered as option
- Enhanced Redundancy: Capable of interlaced connection with two outdoor units, ensuring maximum uptime and reliability.

Technical Data Table

Model no.			TOCWAF40C1	TOCWAF80C2
Cooling capacity	AHRI-540 (min - max)	KW	6.2 – 40.8	6.2 - 82
	EN-12900 (min - max)	KW	5.9 - 39	5.9 – 78
Input power	min-max	KW	1.9 – 16.2	8 – 32.1
Air flow rate		m ³ /h	22000	44000
Fan		Type	Variable Speed Axial EC Fan	
Remote monitoring		-	SNMP / Modbus TCP / Modbus RTU / BACnet	
Refrigerant		Type	R410a	
Water Flow Rate	min-max	m ³ /h	6.2 – 8.3	12.4 – 16.6
Pipe connection	Inlet	mm	1 1/2"	2 1/2"
	Outlet	mm	1 1/2"	2 1/2"
Power supply		-	400 V – 50 Hz – 3 Ph + N + PE	
Dimension	WxHxL	mm	860x1700x990	860x1700x1980
Net weight		kg	300	550



No. 118, West 9 St., Farvardin Blvd., Safadasht Industrial Town
Malard, Tehran, IRAN

(+98) 21 65438141-6

www.abra.energy

© Copyright 2023 ABRA HVAC Products – All rights reserved.
Any part of this publication may be reproduced, copied, filed or transmitted in any shape or form without the permission of ABRA HVAC. Within the policy of continuous improvement of its products, ABRA HVAC reserves the right to make changes at any time without prior notification and without being compelled to introducing them into products subsequently sold. This document may therefore have been subject to amendments during the life of the product.



SCAN ME



POWERED BY:



AFRA
HVAC SYSTEM



ABAN ENERGY